



2018



Sommario

Summary

<u>TENDENZA</u>	21	<u>ACCIAIO</u>	73	<u>THIN</u>	89	<u>TRADIZIONALI</u>	123
<u>TREND</u>		<u>STAINLESS STEEL</u>		<u>THIN</u>		<u>TRADITIONAL</u>	
BLADE	22	STRAIGHT	74	RAKE	90	EXPRESS	124
EIDOS	24	KUBE	76	OPERA2	92	METRO	126
JAM	26	ALFA	77	BLADEQT	94	METRO ROUND	128
TUKE	28	BETA	78	EIDOS QT	96	ATON	130
TUKE GLASS	30	CHRISTINA	79	TUKE QT	98	BUTTERFLY	132
SHARP	32	LOREDANA	80	JAM QT	100	VENERE	134
SWEEP	34	LOREDANA SQUARE	81	JOIN	102	SOFT	136
INNER	36	ADINA	82	IBIS	104	SOFT PLUS	138
LEAF	38	ALESSIA	83	PAVONE	106	NICOLE	140
ICEQ	40	LOFT	84	FENICE	108	NICOLE PLUS	142
ICE PLUS	42	LUCIA	85	FILLO	110	LAGUNA	144
SLIM	43	LUCIA SQUARE	86	BUMP	112	EURO	146
FLOW	44			DUCK	114	UOVO	148
FLOW ROUND	46			KUMA RT	116	APOLLO	150
ARIA	48			KALÈ QT	117	STAR	152
ARIA ROUND	50			SWEEP QT	118	MODULO L	154
KUMA	52			UOVO RT	119	EASY	156
PINAX	54			LEAF RT	120	HALLEY	158
KALÈ	56					300/LP	160
MODULO Q	58					300/LE	161
JOUR	60					RAFFAELLA	162
CHIC	62					LAURA	163
QUEEN	64					MIMOSA	164
NUIT	66						
KING	68						
POMOLINI	70						
						KIT PORTE	167
						SCORREVOLI, POMOLI	
						E ACCESSORI	
						SLIDING DOOR HANDLES, FULL	
						HANDLES & ACCESSORIES	

Indice

ADINA	82	KUBE	76	TUKE QT	98
ALESSIA	83	KUMA	52	UOVO	148
ALFA	77	KUMA RT	116	UOVO RT	119
APOLLO	150	LAGUNA	144	VENERE	134
ARIA	48	LAURA	163	300/LE	161
ARIA ROUND	50	LEAF	38	300/LP	160
ATON	130	LEAF RT	120		
BETA	78	LOFT	84		
BLADE	22	LOREDANA	80		
BLADE QT	94	LOREDANA SQUARE	81		
BUMP	112	LUCIA	85		
BUTTERFLY	132	LUCIA SQUARE	86		
CHIC	62	METRO	126		
CHRISTINA	79	METRO ROUND	128		
DUCK	114	MIMOSA	164		
EASY	156	MODULO L	154		
EIDOS	24	MODULO Q	58		
EIDOS QT	96	NICOLE	140		
EURO	146	NICOLE PLUS	142		
EXPRESS	124	NUIT	66		
FENICE	108	OPERA2	92		
FILLO	110	PAVONE	106		
FLOW	44	PINAX	54		
FLOW ROUND	46	QUEEN	64		
HALLEY	158	RAFFAELLA	162		
IBIS	104	RAKE	90		
ICE PLUS	42	SHARP	32		
ICE Q	40	SLIM	43		
INNER	36	SOFT	136		
JAM	26	SOFT PLUS	138		
JAM QT	100	STAR	152		
JOIN	102	STRAIGHT	74		
JOUR	60	SWEEP	34		
KALÈ	56	SWEEP QT	118		
KALÈ QT	117	TUKE	28		
KING	68	TUKE GLASS	30		

Index

Finiture

Finishes

ITALIANO

ACC	ACCIAIO LUCIDO
ACC SAT	ACCIAIO SATINATO
ACC SAT/CR	ACCIAIO SATINATO/ CROMO LUCIDO
ACC SAT/ CR SAT	ACCIAIO SATINATO/ CROMO SATINATO
ANT	ANTICO
ANT OPACO	ANTICO OPACO
ANTC	ANTICATO
ANTRACITE	ANTRACITE
BI	BLACK IRON
BIANCO	BIANCO
BICOLORE	ACCIAIO BICOLORE
NERO OPACO	NERO OPACO
BR	BRONZO
BT	BRONZO TEND
CR	CROMO LUCIDO
CR/ACC SAT	CROMO LUCIDO/ ACCIAIO SATINATO
CR SAT	CROMO SATINATO
CR SAT/ACC	CROMO SATINATO/ ACCIAIO LUCIDO
CR SAT/CR	CROMO SATINATO/ CROMO LUCIDO
FS	FINITURE SPECIALI*
GR	GREY STONE
IB	INOX BRASS
IC	INOX CHROME
LNL	LONDON NIGHT LUCIDO
LNS	LONDON NIGHT SATINATO
NICK SAT	NICKEL SATINATO VERNICIATO
NICK SAT/NICK	NICKEL SATINATO VERNICIATO/ NICKEL
OLV	OTTONE LUCIDO VERNICIATO
OSV	OTTONE SATINATO VERNICIATO
PERLA/CR	PERLA / CROMO LUCIDO
RCL	FED COPPER LUCIDO
RCS	FED COPPER SATINATO
BI-INOX	BI-INOX

* FS- FINITURE SPECIALI

NERO OPACO
CORTEN
CRACKLÉ
LEATHER
OSSIDATO

ENGLISH

PSS	POLISH STAINLESS STEEL
SSS	SATIN STAINLESS STEEL
SSS/PC	SATIN STAINLESS STEEL/ POLISHED CHROME
SSS/SC	SATIN STAINLESS STEEL/ SATIN CHROME
AB	ANTIQU BRASS
MAB	MATT ANTIQU BRASS
ANTC	ANTICATO (DISTRESSED FINISH)
ANTRACITE	ANTRACITE
BI	BLACK IRON
WHITE	WHITE
BICOLOUR	BICOLOUR STAINLESS STEEL
BLACK MATT	BLACK MATT
BR	BRONZE
BT	BRONZE TEND
PC	POLISHED CHROME
PC/SSS	POLISHED CHROME/ SATIN STAINLESS STEEL
SC	SATIN CHROME
SC/PSS	SATIN CHROME/ POLISHED STAINLESS STEEL
SC/PC	SATIN CHROME/ POLISHED CHROME
FS	SPECIAL FINISHES*
GR	GREY STONE
IB	INOX BRASS
IC	INOX CHROME
LNL	LONDON NIGHT POLISH
LNS	LONDON NIGHT SATIN
SN	SATIN NICKEL
SN/PN	SATIN NICKEL/ NICKEL
PB	POLISHED BRASS
SB	SATIN BRASS
P/PC	PEARL/ POLISHED CHROME
RCL	FED COPPER POLISHED
RCS	FED COPPER SATIN
BI-INOX	BI-INOX

* SF- SPECIAL FINISHES

MATT BLACK
CORTEN
CRACKLÉ
LEATHER
OSSIDATO

La nostra storia

L'azienda Frascio nasce nel 1945 come laboratorio artigianale e negli anni ha seguito costantemente un percorso orientato allo sviluppo e alla ricerca nel settore dei complementi e degli accessori per porte e finestre, fino a raggiungere il mercato internazionale che ad oggi costituisce buona parte della clientela. Frascio rappresenta una realtà sempre in grado di rinnovarsi e guardare al futuro, grazie al continuo aggiornamento nel campo del design, della bioarchitettura e delle innovazioni, riservando una particolare attenzione verso le nuove tecniche di lavorazione, l'utilizzo di nuovi materiali ecologici e nuove finiture.

La collaborazione con importanti designers quali Roberto Semprini, Marcello Ziliani, Simone Micheli, Giulio Iacchetti, Adrian e Jeremy Wright, Giacomo Gustizieri e Brian Sironi ha dato vita ai modelli di punta, che arricchiscono una già ampia serie di impugnature create dall'ufficio di Sviluppo Tecnico interno, con la professionalità e la qualità di sempre. La filosofia aziendale di Frascio è quella di offrire servizi e prodotti che possano soddisfare le più diverse esigenze in materia di complementi e accessori per porte e finestre, e di rinnovarsi restando fedeli alla tradizione, mantenendo un perfetto equilibrio tra la forza produttiva di una grande azienda e la sapienza del gesto artigianale nella cura del prodotto. La cura e la ricercatezza delle rifiniture costituiscono l'unicità della nostra produzione e il nostro punto di forza, come anche l'ampiezza di gamma e di materiali usati.

Uno dei principali punti di forza è la completezza della gamma di prodotti: maniglie per porte e finestre, pomoli, maniglioni, kit per porte scorrevoli, nicchie, nottolini, bocchette, set per la sicurezza, set a standard americano, chiavi, serrature, ferma-porte, coprinterruttori e altri accessori coordinati. I principali materiali utilizzati sono l'ottone, la zama, l'acciaio e l'alluminio. Ma una delle particolarità è rappresentata dall'ampia scelta di finiture, tradizionali e speciali.

Our history

Frascio was founded in 1945 as a small workshop. Thanks to a well-planned process of development and research in the field of furniture and accessories for doors and windows, it has evolved into a company with an international market. Frascio represents a reality always able to renew itself and to look to the future, thanks to a continuous updating in the field of design, bioarchitecture and innovations, paying special attention to the new processing techniques and to the use of newest ecological materials and finishes.

The cooperation with Roberto Semprini, Marcello Ziliani, Simone Micheli, Giulio Iacchetti, Adrian e Jeremy Wright, Giacomo Gustizieri and Brian Sironi founded the top models of this year: they will enrich the complete new line that was created from the internal Planning Office and the Technical Development, with the usual professionalism and quality. The Frascio corporate philosophy is now, more than ever before, to offer a new service to meet each kind of requirements, and to renew itself remaining faithful to traditions, maintaining a perfect equilibrium between the productive force of a big company and the wisdom of an artisan gesture in the care of the product. The high attention to details in finishes and the range of materials used, represent the uniqueness and the strength of our production.

One of the main areas of focus is the wide range of products: handles for doors and windows, knobs, pull handles, sliding door handles, thumbturns, escutcheons, security sets, American standard sets, keys, locks, door-stops, switch plates and other accessories for your home. The materials used are brass, zamak, stainless steel and aluminum. One of the specialties is represented by the large range of both traditional and special finishes.



FRASCIO NEL MONDO

Efficienzasignificacapacitàproduttivamaanche capacitàdistributiva. Per questo Frascio è presente nel mondo con una distribuzione che assicura una fornitura veloce e puntuale, proponendo una gamma completa di prodotti che comprende: maniglie per porte e finestre, coprinterruttori, pomoli, manettoni ed altri articoli coordinati. La vicinanza al cliente ha reso l'azienda un punto di riferimento nei settori dell'architettura e dell'arredo.

FRASCIO IN THE WORLD

Efficiency requires manufacturing capacity, but also effective distribution. This is why Frascio covers the world with a distribution network that ensures precise and prompt supply, offering a complete range of products including: handles for doors and windows, switch covers, knobs, hand levers and other coordinated items. Being close to the customer has made the company a global landmark in the world of architecture and interior decoration.

I Designer



Giacomo Giustizieri

Designer toscano che fonde la sua preparazione tecnica (perito meccanico), alla creatività di 2 lauree in disegno industriale. Amante delle arti e di tutte le loro forme di espressione, dalla letteratura alla fotografia, passando

per la musica e la lettura. Attento osservatore, si definisce “operaio della creatività”, dal momento che crea i suoi progetti facendo sempre attenzione ai vincoli techno-pratici, chiudendoli in forme semplici e lineari.

Curioso e sperimentatore, con la sua figura eclettica ha maturato una pluriennale esperienza a 360° come creativo, vantando collaborazioni presso grandi aziende quali Philips, Osram e Piaggio. Ha collaborato con Ministero degli Affari Esteri Italiano per lo sviluppo di alcuni eventi internazionali a Roma per la promozione della Cultura e Lingua italiana nel mondo. Nel 2011 vince il premio per il design “Presenta un’idea a Guzzini” con la sua lampada modulare “Periscopio”.

Dal 2009 svolge attività di consulenza freelance e insegna disegno e arte in istituti pubblici e privati.



BCF

BCF opera dal 1980. Fin da allora ha mantenuto inalterata come caratteristica peculiare la multidisciplinarietà e la multisettorialità nelle consulenze fornite. Con trent’anni di esperienza alle spalle, BCF rappresenta oggi

uno dei pochi studi di immagine e design che abbia consolidato una profonda cultura di progetto, in grado di offrire una lettura innovativa e contemporaneamente una risposta di sintesi efficace alle problematiche delle imprese. Negli ultimi dieci anni BCF ha ottenuto numerosi riconoscimenti internazionali per il design di prodotto, tra i quali la Menzione d’Onore al Compasso d’Oro 2011.

Designers

Giacomo Giustizieri

Tuscan designer that mixes what he learned in industrial engineering with two industrial design degrees.

He loves all kind of art expressions, from literature to photography, from painting to music. He defines himself as a “creative workman”, because when he projects he pays attention to all the technical binds, creating simple and linear shapes. He is curious and an experimenter, and thanks to his eclectic personality he has a lot of experience as a consultant for large companies such as Philips, Osram and Piaggio.

He has collaborated with the Ministero degli Affari Esteri Italiano to promote with international events in Rome the Italian culture and language in the world.

In 2011 he won the award for “Presenta un’idea a Guzzini” with his modular luminaire “Periscopio”.

Since 2009 he has been teaching design and art in public and private high schools and he has been a freelancer.

BCF

BCF has been operating since 1980. Since then it has always maintained a unique multidisciplinary and multi-sector approach to its consulting operations. Having built up thirty years of experience, BCF has now become one of the few image and design studios to have consolidated a powerful design culture that is capable to offer innovative insight as well as an effective and concise response to business issues and problems.

In the last ten years BCF has obtained several international product design awards, such as the Compasso d’Oro 2011 Honorable Mention.



Marcello Ziliani

Marcello Ziliani nasce a Brescia nel 1963 sotto il segno dei pesci. Nel 1988 si laurea in architettura al Politecnico di Milano con Achille Castiglioni come relatore (e maestro ineguagliato). Dopo tre anni di esperienza all'estero rientra

in Italia e si dedica prevalentemente al design sviluppando progetti per i settori dell'arredamento, del complemento, dell'illuminazione, del bagno, dell'ufficio, dell'oggettistica e della prima infanzia, occupandosi inoltre di allestimenti, coreografie teatrali, art-direction, coordinazione di design, grafica e comunicazione. Non ama gli assolutismi e le sicurezze incrollabili, gli piace guardare le cose con occhi sempre diversi per entrarvi in sintonia, preferisce parlare piano e soprattutto ascoltare. Crede che qualsiasi progetto sia, in fondo, un desiderio, una speranza di volo e che, nonostante le grandi corse che si fanno agitando inutilmente le braccia, prima o poi dieci metri in planata si riescano anche a fare. Come tutti, chi più chi meno, ha messo da parte la dotazione minima indispensabile di premi e riconoscimenti, ha tenuto conferenze, workshop, fatto parte di giurie, mostre, ecc. Dal 2011 insegna design di prodotto all'università di San Marino/IUAV. Ha firmato progetti per Allibert, BBB, Bertocci, Calligaris, Casprini, Ciacci, Ciatti, Domitalia, Donati, Flex, Fou, Flos, Fontana Arte, Frascio, Geuther, Inglesina, Infiniti, ISA, Krios, Krover, Lanzini, Magis, Modo e Modo, Norda, Olympia, Opinion Ciatti, Pali, Parri, Progetti, Papsel, Roche Bobois, Sintesi, Techimpex, Vanini, Views International, Visentin, Zago.

CD
GL

CDGL

Proseguendo una storica collaborazione familiare nata negli anni '60 tra l'architetto Caccia Dominioni e l'azienda guidata in quel momento da Bruno Lualdi, i figli Antonio e Ambrogio, con l'intento di onorare una tradizione entrata a far

parte della cultura del design italiano, lavorano di nuovo insieme per ripensare oggetti di uso quotidiano.

Enrico Gollo da oltre 20 anni si occupa di Industrial design, prima come socio di Piano Design Workshop, in seguito fonda lo studio Ergo Design collaborando negli anni con diverse aziende. I suoi progetti hanno vinto vari premi quali Compasso d'Oro, If Design Award, premio Innovazione ADI Design Index 2016.

Marcello Ziliani

Marcello Ziliani was born in Brescia in 1963 under the sign of Pisces. In 1988 he graduated in architecture at the Politecnico di Milano with Achille Castiglioni as a supervisor (and unmatched teacher). After three years abroad, he returned to Italy and devoted himself mainly to the development of projects for the design of furniture, complement, lighting, bathroom, office, objects and early childhood, working in addition for exhibitions, theatrical choreography, art direction, design coordination, graphics and communication. He doesn't like the absolutism and the indestructible certainties, he loves to look at things with always different eyes to be in tune with them, he prefers to speak softly and, above all to listen. He believes that any project is, after all, a desire, a hope of flight. He believes that, despite the great run you can do waving your arms uselessly, sooner or later you can have your ten meters of gliding. Like all the designers, more or less, he put aside the minimum necessary equipment of prizes and awards, he has given lectures, workshops, he served on juries and so on. Since 2011 he's been a professor of product design at the University of San Marino / IUAV. He signed projects for Allibert, BBB, Bertocci, Calligaris, Casprini, Ciacci, Ciatti, Domitalia, Donati, Flex, Fou, Flos, Fontana Arte, Frascio, Geuther, Inglesina, Infiniti, ISA, Krios, Krover, Lanzini, Magis, Modo e Modo, Norda, Olympia, Opinion Ciatti, Pali, Parri, Progetti, Papsel, Roche Bobois, Sintesi, Techimpex, Vanini, Views International, Visentin, Zago.

CDGL

Following a historic family collaboration born in the 60s between the architect Caccia Dominioni and the company led at that time by Bruno Lualdi, the sons Anthony and Ambrose, with the intent to honor a tradition become part of the culture of the Italian design, work again together in rethinking everyday objects.

Enrico Gollo has been dealing for over 20 years with Industrial Design, previously as a design partner of Piano Workshop, later founding the Ergo Design studio that has collaborated over the years with various companies.

His designs have won several awards such as Golden Compass, If Design Award, Innovation Award ADI Design Index 2016.



Adrian e Jeremy Wright

Design Wright è lo studio dei fratelli Adrian e Jeremy Wright con base a Londra. Specializzati nel design per arredamento di interni e accessori, grazie al loro background di studi in ingegneria, riescono a catturare tutti gli aspetti, visivi e tecnici,

dei prodotti che vanno a realizzare. Sono un piccolo laboratorio di idee, con un forte carattere, che consente loro di spaziare in varie discipline senza alcun limite.

Adrian e Jeremy Wright

Design Wright is the London-based design practice of the English brothers Adrian and Jeremy Wright. Specialized in product and furniture design, thanks to their background in engineering, their work is often characterized by their appreciation of both the visual and technical aspects of a project. They're a small but professional practice working across a wide range of design disciplines, and they welcome projects of all size and can advise on any creative matter.



Brian Sironi

Brian Sironi nasce a Seregno (MI) nel 1977. Si laurea in Design al Politecnico di Milano e prosegue la sua formazione collaborando con architetti e designer. Il suo percorso formativo si colloca nel cuore della Brianza, a contatto con varie

professionalità del sistema-design: falegnami, fabbri, intagliatori, tappezzieri. Una formazione metà artigianale e metà accademica, con un radicamento sul territorio che è parte integrante del suo progetto di designer italiano e cosmopolita. Infatti prosegue il suo percorso negli Stati Uniti e al suo ritorno, nel gennaio del 2008, fonda il suo Studio Brian Sironi, specializzato in product design, interior design e architettura. Nel suo lavoro si concentra sulla connessione tra oggetto e utilizzatore, forma e funzione, puntando alla forma nella sua purezza. Nel 2009 vince il premio "Design dello stupore" al concorso "Young & Design", nel 2010 ottiene molti altri riconoscimenti, come i premi internazionali "If Gold Award", "Good Design Award" e "Red Dot Design Award". A soli 33 anni, nell'edizione del 2011, vince il "Compasso d'Oro" per la lampada "Elica" prodotta da "Martinelli Luce".

Brian Sironi

Brian Sironi was born in Seregno (Italy) in 1977. He graduated at the Politecnico in Milan with a degree in Industrial Design and then began collaborating with architects, designers and professional artisans in the design industry such as carpenters, blacksmiths, wood carvers and upholsterers. Trained in the heart of Brianza, his background is both practical and academic with a strong connection to the territory, an integral element featured in his cosmopolitan Italian designs. In 2007, Brian continued his training in the United States and after his return to Italy, he established his own firm, Studio Brian Sironi, specialized in product design, interior design and architecture. In his work, he focuses on the connection between object and user, shape and function, while aiming for form in his purity. In 2009 he received the special prize "Il Design dello Stupore" in the Contest "Young & Design", in 2010 he received many other awards, such as the prestigious "IF Gold Award", "Good Design Award" and "Red Dot Design Award". At the age of 33 he won the "Compasso d'Oro Edition 2011" award for the lamp "Elica" produced by "Martinelli Luce".



Controdesign

Fondato nel 1989 da Marcella Spinelli e Marcello Oggioni, lo Studio Controdesign nel corso degli anni ha collaborato con numerose aziende prevalentemente nel settore dell'arredamento, progettando prodotti di design.

Controdesign

Founded in 1989 by Marcella Spinelli and Marcello Oggioni, Studio Controdesign has worked over the years with many companies, mainly in the furniture industry, planning design products.



Simone Micheli

Simone Micheli fonda l'omonimo Studio d'Architettura nel 1990 e nel 2003 la società di progettazione "Simone Micheli Architectural Hero" con sede a Firenze e Milano. La sua attività professionale si articola in plurime direzioni: dall'architettura

all'architettura d' interni, dal design al visual design passando per la comunicazione; le sue creazioni, sostenibili e sempre attente all'ambiente, sono connotate da forte identità e unicità. Le numerose realizzazioni per pubbliche amministrazioni e importanti committenze private connesse al mondo residenziale e della collettività, ne fanno uno dei principali attori nella dimensione progettuale europea. Molte sono le pubblicazioni su riviste italiane e internazionali, le interviste televisive dedicate alla sua opera e le monografie, tra cui "Simone Micheli From the Future to the Past", edita nel 2012, che rappresenta una selezione di 20 anni del suo fare progettuale.



Giulio Iacchetti

Giulio Iacchetti, nato nel 1966, si occupa di industrial design dal 1992. All'attività di progettista alterna l'insegnamento presso numerose università e scuole di design, in Italia e all'estero. Caratteri distintivi del suo fare sono la ricerca e la

definizione di nuove tipologie oggettuali, come il Moscardino, posata multiuso biodegradabile per cui, nel 2001, si aggiudica, con Matteo Fagni, il Compasso d'Oro ed entrata a far parte della collezione permanente del design al MoMA di New York. Con l'ideazione e il coordinamento del progetto collettivo Eureka Coop, realizzato per Coop Italia, ha portato il design nella grande distribuzione organizzata e caratterizzato la nuova generazione del design italiano. Nel 2009 questo progetto gli è valso il Premio dei Premi per l'innovazione conferitogli dal Presidente della Repubblica Italiana. All'attività di progettista si aggiunge la direzione artistica per importanti marchi come iB rubinetterie, ceramica Globo e il Coccio design edition. Per Corraini Edizioni ha curato il libro Italianità, una raccolta di interventi relativi agli oggetti, ai simboli, agli odori, ai sapori e ai suoni che contribuiscono a formare la coscienza del popolo italiano. Nel maggio 2009 la Triennale di Milano ha ospitato una sua mostra personale intitolata "Giulio Iacchetti. Oggetti disobbedienti".

Simone Micheli

In 1990 he founded the architectural studio that bears his name, and in 2003 the architecture and design company "Simone Micheli Architectural Hero", based in Florence and Milan. His professional activity moves in different directions: from architecture to interior design, and from industrial design to visual design going through mass-media and social media. His creations, ecofriendly and oriented to nature, are defined by strong identity and uniqueness. There are many publications on Italian and international magazines, television interviews dedicated to his works and monographs, such as "Simone Micheli from the Future to the Past", published in 2012, which represents a selection of his 20 years of design activity.

Giulio Iacchetti

Giulio Iacchetti, born in 1966, has worked in the field of industrial design since 1992. He alternates this activity with teaching in many universities and schools of design in Italy and abroad. The distinctive characteristics of his work are research and definition of new object typologies, like the Moscardino, the multiuse biodegradable utensil for which in 2001, together with Matteo Fagni, he won the Compasso d'Oro, with the object becoming part of the permanent design collection of MoMA New York. The concept and coordination of the group project Eureka Coop, for Coop Italia, brought design into the major retailing circuit and focused on the new generation of Italian design. In 2009 this project won the Premio dei Premi for the innovation bestowed by the President of the Italian Republic. He works as art director for important brands like iB rubinetterie, Ceramica Globo and Il Coccio design edition. For Corraini Edizioni he has edited the book "Italianità", a collection of contributions on objects, symbols, odors, flavors and sounds that contribute to form the consciousness of the Italian people. In May 2009 the Milan Triennale held a solo show of his work entitled "Giulio Iacchetti. Disobedient Objects".



Roberto Semprini

Nato a Fimini nel 1959, Roberto Semprini studia architettura a Firenze. Nel 1987 aderisce al movimento Bolidista, che esprime il design in chiave simbolica e come sintesi di un concetto di velocità elettronica. Trasferitosi a Milano

inizia a collaborare come giornalista freelance per alcune riviste di design come *Modo*, *L'Atelier* (Parigi) e *AFDI* (Barcellona). Nel 1989 esce il divano "Tatlin" di Edra, che risulta tra i prodotti vincitori del prestigioso premio TOP TEN a Dusseldorf. Nel 1994 con il tavolino "Manta" per Fiam è tra i vincitori del premio Young & Design.

I suoi prodotti fanno parte della collezione permanente del Montreal Museum of Decorative Arts in Canada e del New Museum of Design di Londra. Nel 2000 si trasferisce a Fimini dove inaugura lo spazio "FM 12 art & design", Galleria d'arte e Studio di Design e Architettura di Interni. Dal 2006 lo studio realizza scenografie di grande impatto, inerenti la ricerca di nuovi spazi domestici e pubblici, all'interno della parte culturale di eventi fieristici come il Sia di Fimini, il Fuori Salone di Milano, *Abitare il Tempo* a Verona e *Sun* di Fimini. Nel 2007 è stato invitato dal Seoul Living design Fair (Korea) ad esporre "La casa Italo/coreana". Ha collaborato con numerose aziende di design come Fiam, Moroso, Alivar, Pede Guzzini, Edra, Ciacci, R.S.V.P., Arredaesse, Sicis, Slide, Trivellini, Contempo, Ciacci Kreaty, Larms, Spaus, Ad Hoc, M.B., Gruppo Trend, Frighetto, Dilmos, Adrenalina, Morfeus, Mastella Design, Pedrali, Morellato, Scab, Valdichienti ecc. Ha tenuto conferenze e seminari in diverse facoltà di design come: facoltà di Architettura di Firenze, Politecnico di Milano, Scuola Superiore di Progettazione dell'Università degli Studi di Bologna, I.E.D. di Milano, I.A.V. di Orleans e Scuola Elisava di Barcellona, ecc. Attualmente è docente di ruolo e Coordinatore del Corso di Progettazione Artistica per l'Impresa all'Accademia di Belle Arti di Brera.

Roberto Semprini

Born in Fimini in 1959, Roberto Semprini studied architecture in Florence. In 1987 he joined the Bolidismo trend that expresses the design in a symbolic and synthesis of a concept of electronic speed. He moved to Milan and started working as a freelance journalist for several design magazines like *Mode*, *L'Atelier* (Paris) and *AFDI* (Barcelona). In 1989, he realized the sofa "Tatlin" Edra, which is one of the winners of the prestigious TOP TEN in Dusseldorf. In 1994, with the table "Manta" for Fiam is among the winners of the Young & Design. His products are part of the permanent collection of the Montreal Museum of Decorative Arts in Canada and the New Museum of Design in London. In 2000 he moved to Fimini, where he launched the space "FM 12 Art & Design" Gallery and Studio of Design and Interior Architecture. Since 2006 the studio has realized high-impact scenography, regarding the search for new domestic and public spaces, within cultural events such as exhibitions SIA in Fimini, *Fuori Salone del Mobile* in Milan, *Abitare il Tempo* in Verona and *Sun* in Fimini. In 2007 he was invited by the Seoul Living Design Fair (Korea) to exhibit "The Italian / Korean house." He has collaborated with numerous design firms like Fiam, Moroso, Alivar, Pede Guzzini, Edra, Ciacci, RSVP, Arredaesse, Sicis, Slide, Trivellini, Contempo, Ciacci Kreaty, Larms, Spaus, Ad Hoc, MB, Trend Group, Frighetto, Dilmos, Adrenaline, Morfeus, Mastella Design, Pedrali, Morellato, Scab, Valdichienti etc. He has given lectures and seminars in various faculties of design such as the Faculty of Architecture in Florence, the Polytechnic in Milan, the School of Engineering, the University of Bologna, the I.E.D. in Milan, the I.A.V. in Orleans and the School Elisava Barcelona, etc. He is currently role Professor and Coordinator of the Artistic Project Class for the Business Academy of Fine Arts in Brera.





La nostra ricerca

Lo Studio di Progettazione e Sviluppo Tecnico è un vero e proprio laboratorio di ricerca. I nostri tecnici creano prodotti nuovi e rielaborano modelli classici per aggiornarli, all'occorrenza, secondo le richieste del mercato. Questo reparto ci consente inoltre di progettare articoli su misura per aziende partner, come produttori di porte e finestre, e di sviluppare giorno dopo giorno la ricerca dei materiali. Un nuovo elemento è la collaborazione con creativi, grafici, architetti e designers esterni, per la creazione di articoli particolari e la realizzazione di progetti innovativi. Grazie a queste partnership continua il nostro percorso nel mondo del design, perché siamo fortemente convinti che rinnovarsi ed evolvere siano le carte vincenti per stare sempre al passo con i tempi ed essere davvero competitivi. Tutti i nostri clienti oggi ci riconoscono un merito: aver realizzato un perfetto equilibrio tra la forza produttiva di una grande azienda e la sapienza del gesto artigianale nella cura del prodotto. Due mondi che sanno dialogare e interagire: il pensiero che progetta, che pianifica e la mano esperta che produce, che guida la tecnologia e trasmette ad ogni singolo pezzo i valori del marchio Frascio: il design, la cura delle finiture, la qualità del prodotto. Una grande organizzazione che genera una produzione di maniglie ed accessori in linea con le esigenze e le aspettative del cliente per volumi di prodotto e tempi di consegna.

LA TECNOLOGIA E LA SICUREZZA

Da sempre attenti ai singoli elementi della produzione, abbiamo sviluppato al nostro interno un sistema finalizzato a garantire elevati standard qualitativi. Personale altamente qualificato che si dedica alla ricerca continua di nuove soluzioni, tecnici di grande esperienza che sviluppano i prodotti, selezionano i materiali ed effettuano test e continui controlli e collaudi sui pezzi durante la lavorazione.

Our research

Our technical Project and Development department is a research laboratory where technicians create new products and revise classic models according to market requirements. This office also creates O.E.M. products for commercial partners, including door and window manufacturers, and creates new designs in cooperation with graphic designers and architects, to support innovative projects. Thanks to these partnerships, we continue our journey round the world of design, because we believe that renewal and progress are essential to our continuous competitiveness.

All our customers now recognize one of our points of excellence: the perfect balance between the manufacturing power of a great company and the skilled eye and hand of our craftsmen. Two worlds that interact and intertwine: the mind that plans and designs, the human hand that guides technology and impresses upon each individual item the philosophy of Frascio - beautiful design, perfect finish, absolute quality. A great organization which creates handles and accessories to meet the demands and expectations of customers also in terms of volumes and delivery times.

TECHNOLOGY AND SAFETY

Always paying attention to each aspect of the production, we have created an internal system to ensure the highest levels of quality. Expert research staff works constantly to discover new solutions, highly experienced technicians develop products, select materials and constantly carry out tests, monitoring products all the way through the production cycle.

UNI ISO 9001:2015

E' garanzia di qualità e sicurezza per i clienti la certificazione UNI ISO 9001/2015, con la quale l'azienda testimonia il suo impegno e volontà di offrire e mantenere standard produttivi di ottimo livello.

UNI ISO 9001:2015

It is quality and safety guarantee for customers the UNI ISO9001/2015 certification, with which the company demonstrates its commitment and willingness to offer and maintain high-quality production standards.



FINITURE

Dopo oltre 70 anni, Frascio non perde la sua attenzione per le nuove tendenze e le nuove tecnologie, proponendo sempre nuovi prodotti e nuove finiture al passo con le mode e le tradizioni, ricreando materiali e suggestioni tutte da scoprire.

L'irregolare trama del cuoio invecchiato, l'architettonico Corten e le finiture PVD antigraffio su base cromata e perla che regalano colori unici, senza dimenticare il modaiolo antracite.

FINISHES

After 70 years, Frascio doesn't lose its attention for new trends and new technologies and proposes new products and new finishes in line with fashions and traditions, recreating materials and suggestions all to be discovered.

The irregular texture of old leather, the architectural Corten, the PVD anti-scratch finishes on a chrome or pearl basis, that give unique colours, without forgetting the trendy antracite.



PVD

La costante ricerca nel campo delle tecnologie ci ha consentito di mettere a punto speciali lavorazioni. Una di queste è il trattamento PVD, che ci permette di realizzare le finiture INOX BRASS®, INOXBRONZE® e INOX CHROME®, che rendono le superfici inossidabili e i prodotti inattaccabili dagli agenti esterni. Inoltre, test e regolari controlli durante il ciclo di lavorazione assicurano gli elevati standard qualitativi, che contraddistinguono da sempre la nostra produzione.

La certificazione di sistema è garantita da DNV secondo le norme UNI EN ISO 9001:2008.

PVD

Through constant research in technology, we have been able to improve our processes. By using advanced PVD technology we can produce INOX BRASS®, INOXBRONZE® and INOX CHROME® finishes, which render the surface impregnable against damage from normal use such as oxidation, wear and abrasion. Moreover, tests and regular checks during the production cycle ensure the highest levels of quality, which have always distinguished our production.

The quality management system is certified by DNV accordingly to UNI EN ISO 9001:2008.



ANTRACITE BY FRASCIO

Frascio ha sviluppato una nuova finitura, Antracite, realizzata su base satinata tramite la tecnologia PVD (Physical Vapor Deposition o deposizione fisica da vapore) che protegge la superficie del prodotto dai graffi e dall'usura del tempo e viene garantita per 15 anni. La finitura è proposta su un numero selezionato di prodotti a catalogo e associata al nuovo sistema di rosetta bassa Thin, sia tonda sia quadrata, alta solo 5 mm. Tra i prodotti: la nuova Join (design Giacomo Gustizieri) e prodotti di riferimento come Ibis, Pavone, Fenice (rispettivamente progettati da Giulio Iacchetti, Controdesign e Marcello Ziliani).

ANTRACITE BY FRASCIO

Frascio has developed a new finish - Antracite - realized on a satin base through PVD (Physical Vapor Deposition) technology, which protects the surface of the product from scratches, wear and tear, with 15 years warranty. The finish is available for a limited number of products, and associated to the new low-profile rose system THIN introduced by Frascio, round or squared, 5 mm thickness. Among the products: Join (design Giacomo Gustizieri) and reference products like Ibis, Pavone, Fenice (respectively designed by Giulio Iacchetti, Controdesign and Marcello Ziliani).

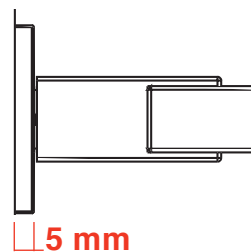
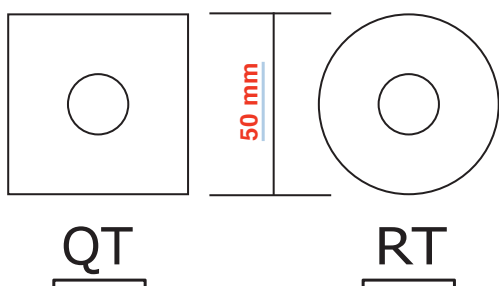

THIN

Thin è il nuovo sistema di rosetta bassa progettato da Frascio che permette di avere bassi spessori senza ulteriori lavorazioni sulla porta.

- montaggio veloce e pulito
- NO lavorazioni aggiuntive, NO polveri residue
- spessore 5 mm

THIN

Thin is the new low-profile rose system introduced by Frascio, low profile thickness and ready to install without additional modifications on the door.

- Fast and clean to install
- NO additional drilling steps required and therefore NO mess
- Thickness 5 mm



**TENDENZA
TREND**

Blade



ZAMA/ZAMAK



Brian Sironi design



1500/50 Q

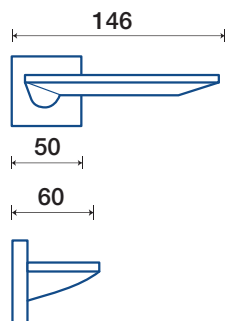

1500/32 QDK

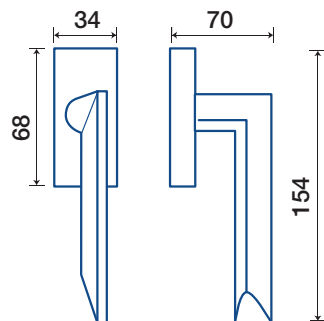

CROMO LUCIDO
POLISHED CHROME



CROMO SATINATO
SATIN CHROME



BIANCO
WHITE



NERO OPACO
MATT BLACK



OSSIDATO
OSSIDATO



CORTEN
CORTEN



CRACKLÉ
CRACKLÉ



LEATHER
LEATHER



LONDON NIGHT LUCIDO
LONDON NIGHT POLISHED



LONDON NIGHT SATINATO
LONDON NIGHT SATIN



FED COPPER LUCIDO
FED COPPER POLISHED



FED COPPER SATINATO
FED COPPER SATIN



GREY STONE
GREY STONE



BRONZO TEND
BRONZE TEND



NICKEL SATINATO
SATIN NICKEL



Eidos



ZAMA/ZAMAK



Brian Sironi design



630/50 Q

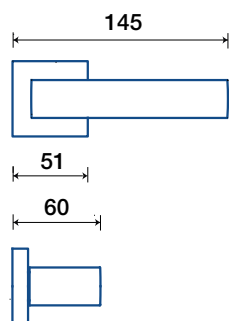

630/32 Q DK

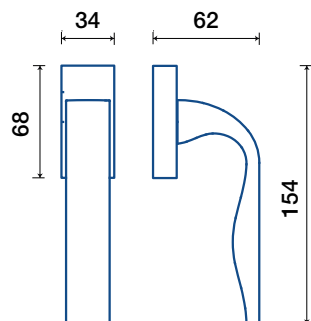

CROMO LUCIDO
POLISHED CHROME



CROMO SATINATO
SATIN CHROME



BIANCO
WHITE



NERO OPACO
MATT BLACK



OSSIDATO
OSSIDATO



CORTEN
CORTEN



CRACKLÉ
CRACKLÉ



LEATHER
LEATHER



LONDON NIGHT LUCIDO
LONDON NIGHT POLISHED



LONDON NIGHT SATINATO
LONDON NIGHT SATIN



FED COPPER LUCIDO
FED COPPER POLISHED



FED COPPER SATINATO
FED COPPER SATIN



GREY STONE
GREY STONE



BRONZO TEND
BRONZE TEND



NICKEL SATINATO
SATIN NICKEL



Jam



ZAMA/ZAMAK



Frascio design



639/50 Q

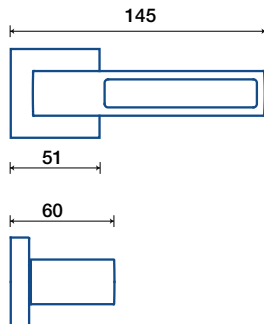

639/32 Q DK

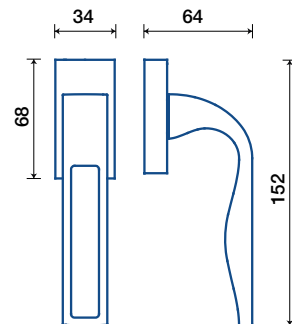

CROMO LUCIDO
POLISHED CHROME



CROMO SATINATO
SATIN CHROME



NICKEL SATINATO
SATIN NICKEL



BRONZO TEND
BRONZE TEND



FED COPPER LUCIDO
FED COPPER POLISHED



FED COPPER SATINATO
FED COPPER SATIN



LONDON NIGHT LUCIDO
LONDON NIGHT POLISHED



LONDON NIGHT SATINATO
LONDON NIGHT SATIN



GREY STONE
GREY STONE



Tuke



ZAMA/ZAMAK



Brian Sironi design



620/50 Q

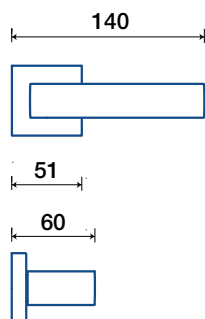

620/32 Q DK

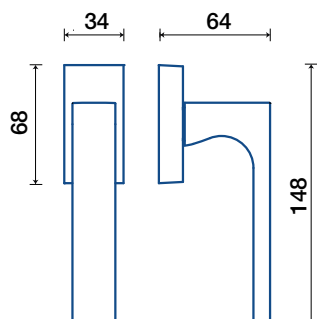

CROMO LUCIDO
POLISHED CHROME



CROMO SATINATO
SATIN CHROME



BIANCO
WHITE



NERO OPACO
MATT BLACK



OSSIDATO
OSSIDATO



CORTEN
CORTEN



CRACKLÉ
CRACKLÉ



LEATHER
LEATHER



LONDON NIGHT LUCIDO
LONDON NIGHT POLISHED



LONDON NIGHT SATINATO
LONDON NIGHT SATIN



FED COPPER LUCIDO
FED COPPER POLISHED



FED COPPER SATINATO
FED COPPER SATIN



GREY STONE
GREY STONE



BRONZO TEND
BRONZE TEND



NICKEL SATINATO
SATIN NICKEL



Tuke Glass

ZAMA/ZAMAK



Brian Sironi design



625/50 Q

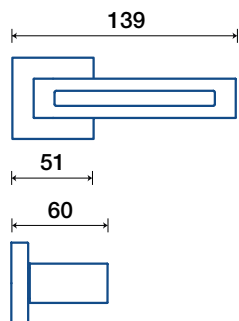

625/32 Q DK

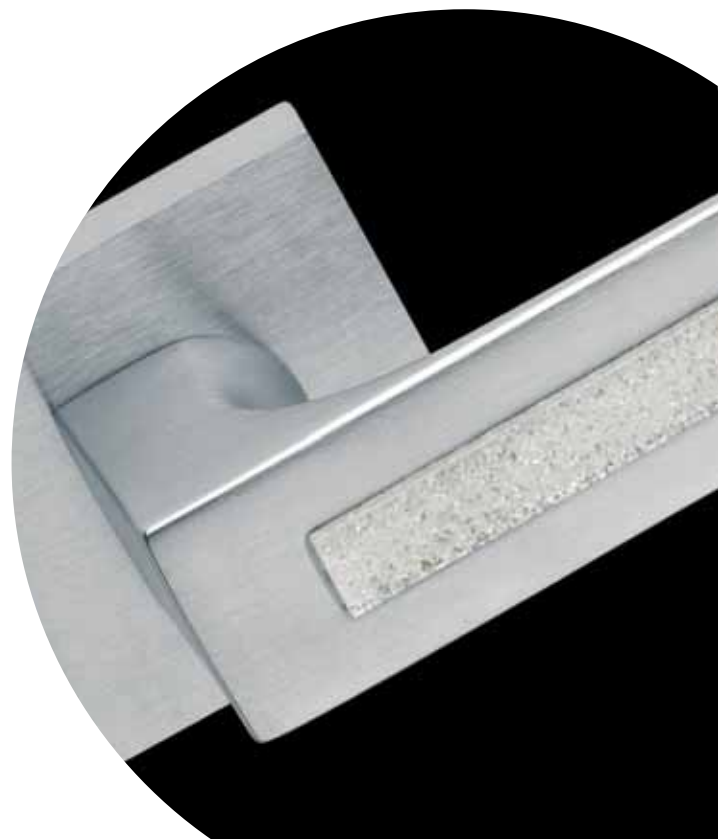
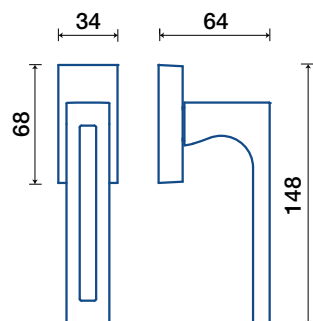

CROMOLUCIDO
POLISHED CHROME



CROMOSATINATO
SATIN CHROME



CROMOLUCIDO
POLISHED CHROME



CROMOSATINATO
SATIN CHROME



CROMOLUCIDO
POLISHED CHROME



CROMOSATINATO
SATIN CHROME



Sharp

ZAMA/ZAMAK



Brian Sironi design



1580/50 QR

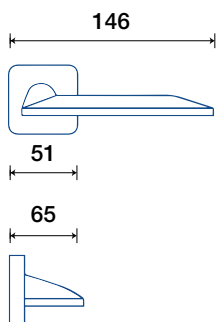

1580/32 DK

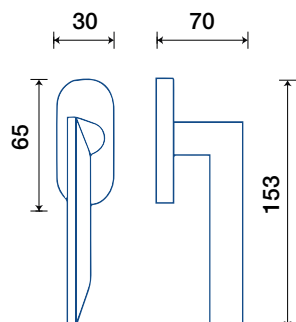

CROMOLUCIDO
POLISHED CHROME



CROMOSATINATO
SATIN CHROME



Sweep

OTTONE/BRASS



Roberto Semprini design



720/50 Q

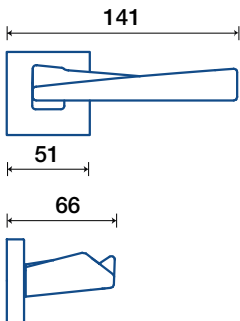

720/32 Q DK

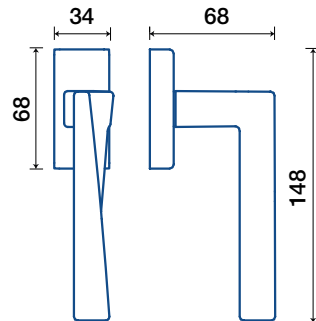

CROMOLUCIDO
POLISHED CHROME



CROMOSATINATO
SATIN CHROME

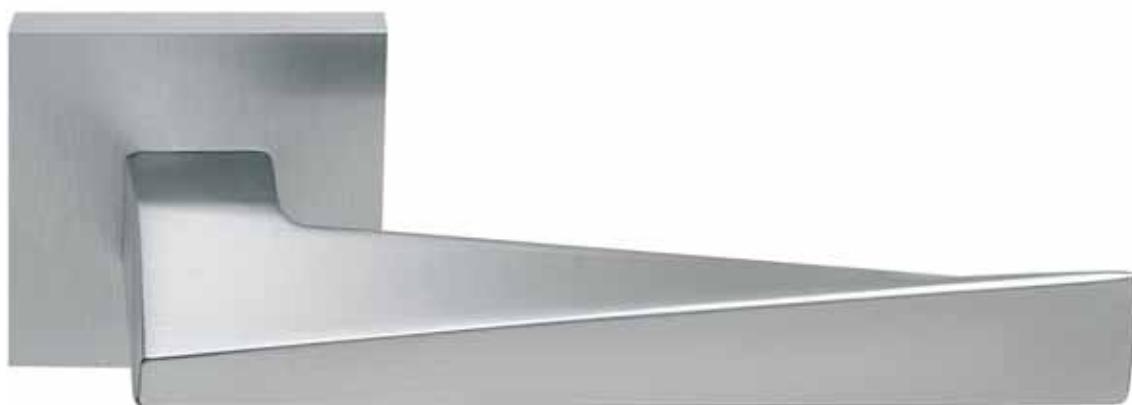

Inner

ZAMA/ZAMAK



Brian Sironi design



660/50 QR

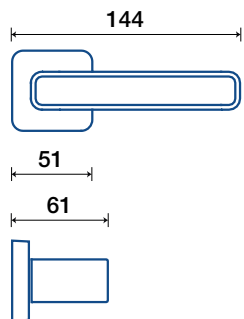

660/32 DK

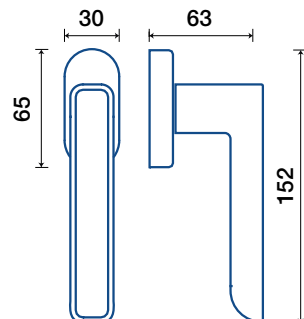

INNERMETAL



CROMO LUCIDO
POLISHED CHROME



CROMO SATINATO
SATIN CHROME



INNERGLASS



CROMO LUCIDO
POLISHED CHROME



CROMO SATINATO
SATIN CHROME



INNERWOOD
WENÇE



CROMO LUCIDO
POLISHED CHROME



CROMO SATINATO
SATIN CHROME



INNERWOOD
FOME/OAK



CROMO LUCIDO
POLISHED CHROME



CROMO SATINATO
SATIN CHROME



Leaf

ZAMA/ZAMAK



Brian Sironi design



1520/50 I

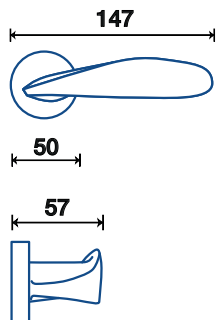

1520/32 DK

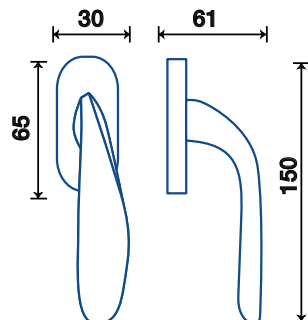

CROMO LUCIDO
POLISHED CHROME



CROMO SATINATO
SATIN CHROME



ANTICO PAVO
MATT ANTIQUE BRASS



Ice Q

ZAMA/ZAMAK



Frascio design



1540/50 QR

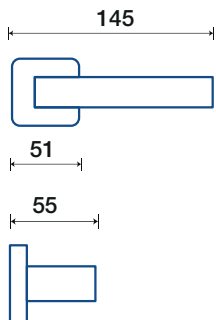

1540/31 QDK

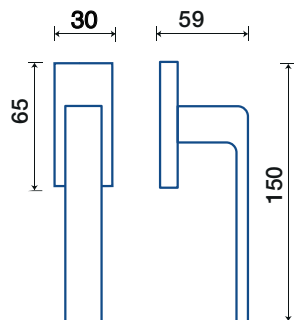

CROMOLUCIDO
POLISHED CHROME



CROMOSATINATO
SATIN CHROME



Ice Plus

CROMOSATINATO/ CROMOLUCIDO
SATIN CHROME/ POLISHED CHROME

ZAMA/ZAMAK



Frascio design



1550/50 QR

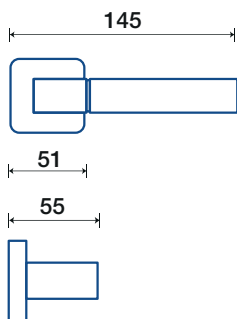

1550/31 QDK

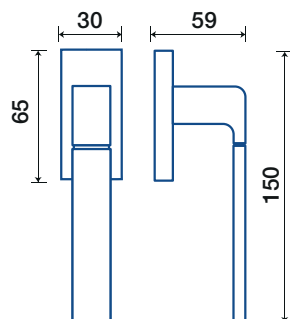

Slim

CROMOLUCIDO
POLISHED CHROME

ZAMA/ZAMAK



Simone Micheli design



1560/50 I

150



51



Frascio

Flow

OTTONE/BRASS



Adrian e Jeremy Wright design



700/50 QR

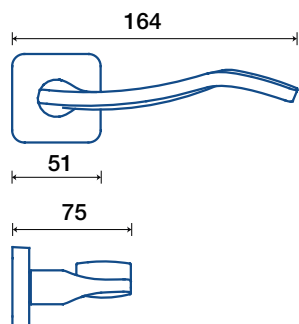

700/32 DK

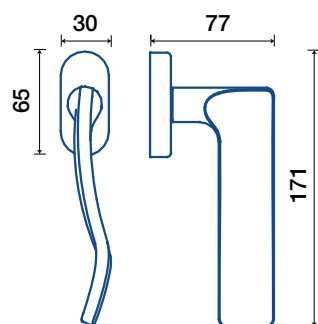

CROMOLUCIDO
POLISHED CHROME



CROMOSATINATO
SATIN CHROME



Flow Round

OTTONE/BRASS



Adrian e Jeremy Wright design



700/50 I

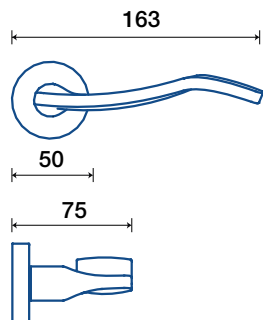

700/32 DK

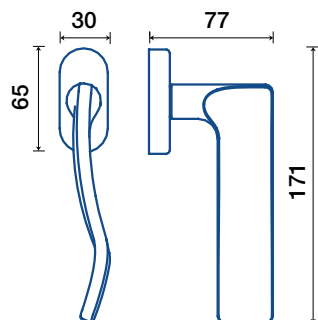

CROMOLUCIDO
POLISHED CHROME



CROMOSATINATO
SATIN CHROME



Aria

OTTONE/BRASS



Brian Sironi design



710/50 QR

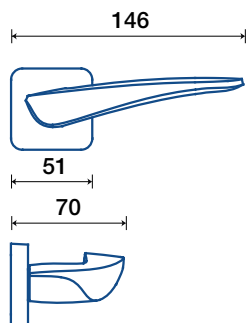

710/32 DK

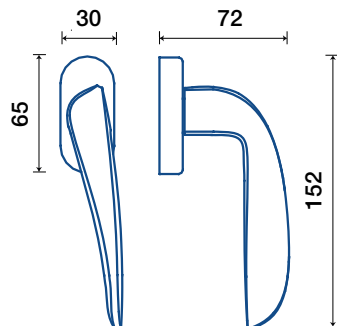

CROMOLUCIDO
POLISHED CHROME



CROMOSATINATO
SATIN CHROME



Aria Round

OTTONE/BRASS



Brian Sironi design

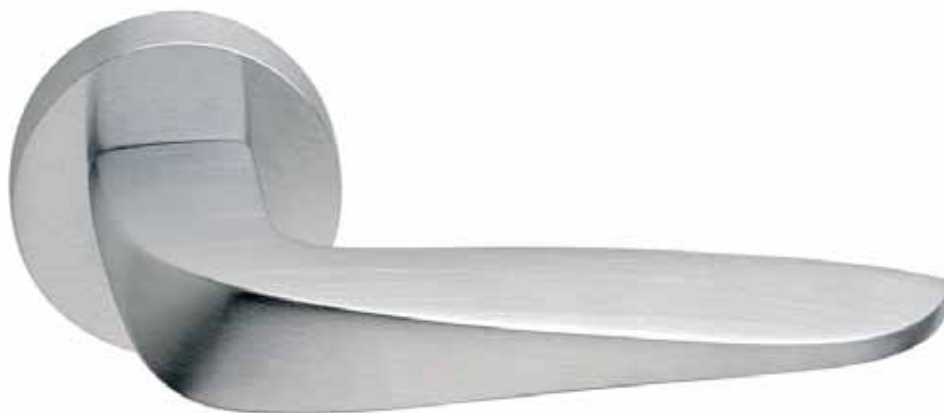

710/50 I

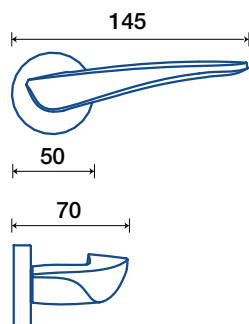

710/32 DK

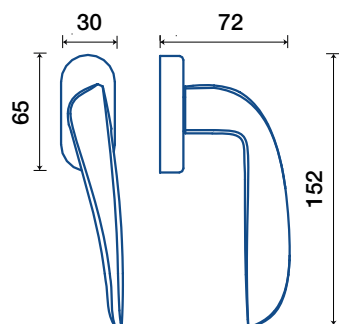

OTTONE LUCIDO VERNICIATO
POLISHED BRASS



CROMO SATINATO
SATIN CHROME

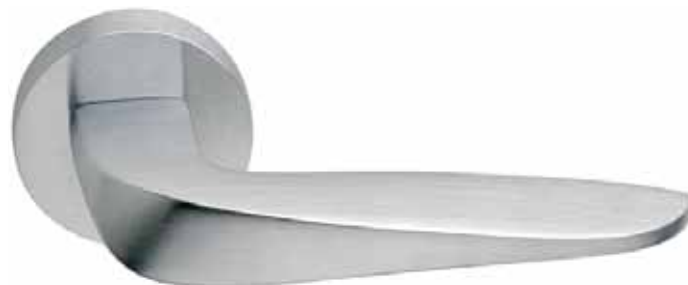

ANTICO PACO
MATT ANTIQUE BRASS



Kuma

OTTONE/BRASS



Brian Sironi design



640/50 I

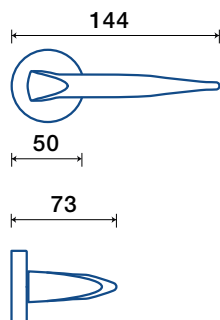

640/32 DK

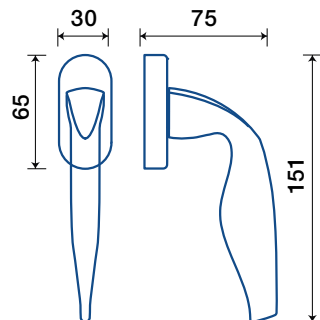

CROMO LUCIDO
POLISHED CHROME



CROMO SATINATO
SATIN CHROME



OTTONE LUCIDO VERNICIATO
POLISHED BRASS



ANTICO OPACO
MATT ANTIQUE BRASS



Pinax

ZAMA/ZAMAK



Brian Sironi design



610/50 Q

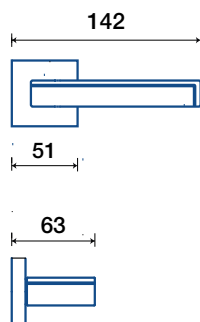

610/32 QDK

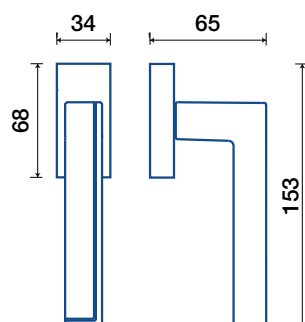

CROMOSATINATO E LUCIDO
SATIN AND POLISHED CHROME



CROMOSATINATO
SATIN CHROME

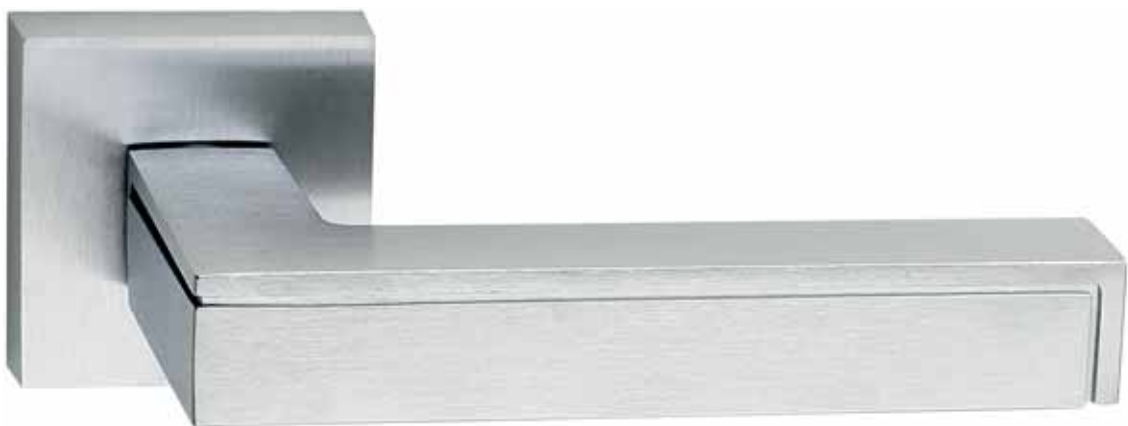

Kalè

ZAMA/ZAMAK



Frascio design



650/50 Q

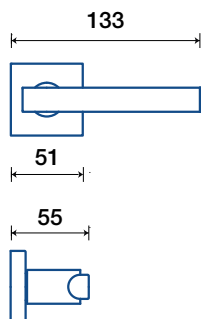

650/32 Q DK

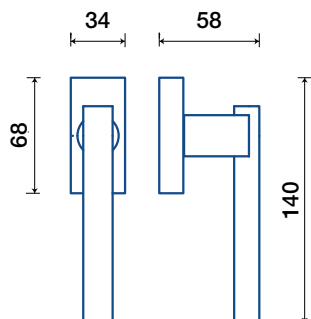

CROMOLLUCIDO
POLISHED CHROME



CROMOSATINATO
SATIN CHROME



CROMOSATINATO / CROMOLLUCIDO
SATIN CHROME / POLISHED CHROME



Modulo Q

OTTONE/BRASS



Frascio design



745/50 Q

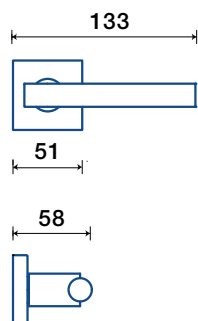

745/32 Q DK

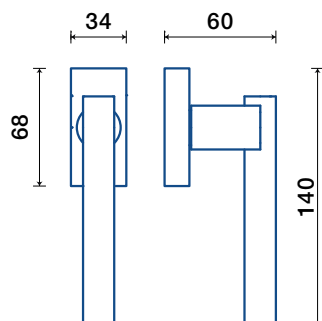

CROMOLUCIDO
POLISHED CHROME

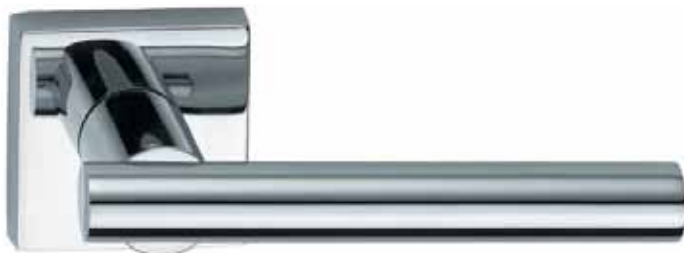

CROMOSATINATO
SATIN CHROME



CROMOSATINATO / CROMOLUCIDO
SATIN CHROME / POLISHED CHROME



Jour

ZAMA/ZAMAK



Frascio design



633/50 Q

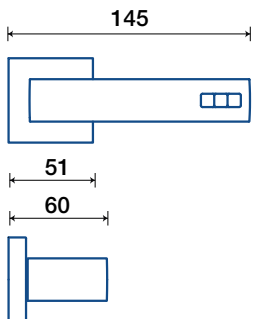

633/32 Q DK

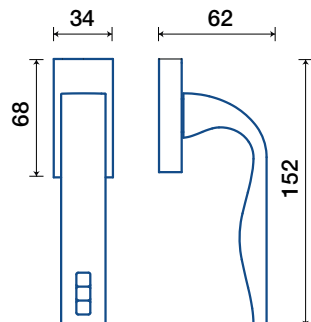

Frascio

CROMOLUCIDO
POLISHED CHROME



CROMOSATINATO
SATIN CHROME



BRONZO TREND
BRONZE TREND



Chic

ZAMA/ZAMAK



Frascio design



631/50 Q

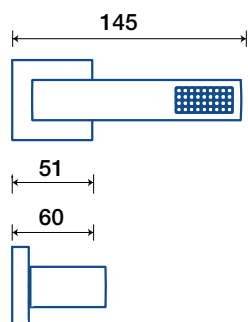

631/32 QDK

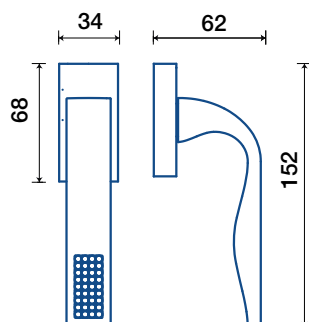

CROMOLUCIDO
POLISHED CHROME



CROMOSATINATO
SATIN CHROME



BRONZO TREND
BRONZE TREND



Queen

ZAMA/ZAMAK



Frascio design

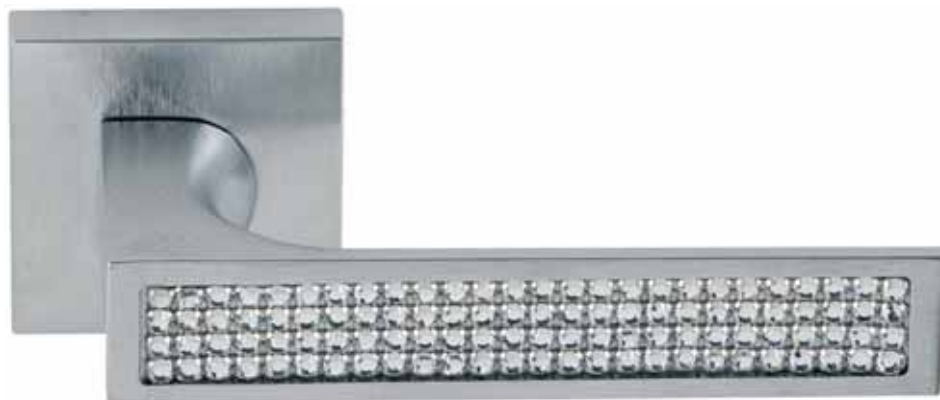

621/50 Q

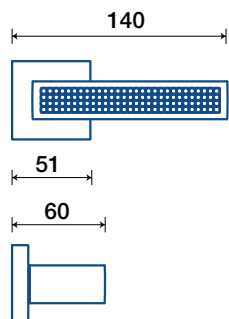

621/32 Q DK

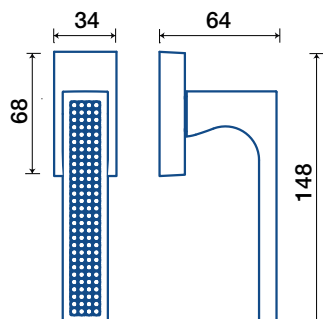

CROMOLUCIDO
POLISHED CHROME



CROMOSATINATO
SATIN CHROME



BRONZO TREND
BRONZE TREND



Nuit

ZAMA/ZAMAK



Frascio design



632/50 Q

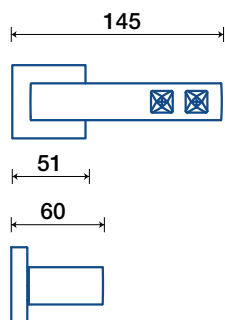

632/32 Q DK

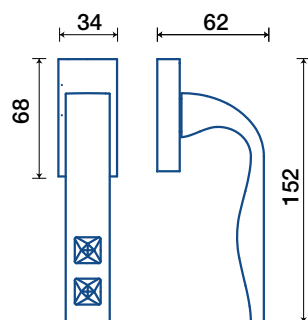

CROMOLUCIDO
POLISHED CHROME



CROMOSATINATO
SATIN CHROME



BRONZO TREND
BRONZE TREND



King

ZAMA/ZAMAK



Frascio design



623/50 Q

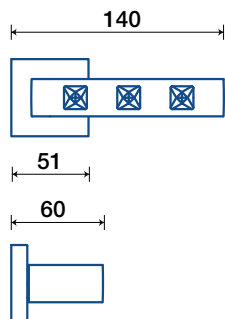

623/32 Q DK

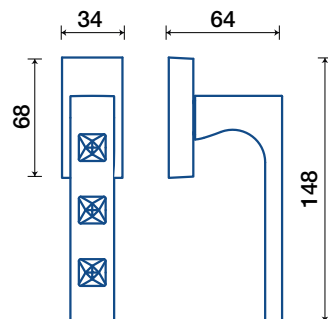

CROMOLUCIDO
POLISHED CHROME



CROMOSATINATO
SATIN CHROME



BRONZO TREND
BRONZE TREND



18/1

Pomolini per mobili / Forniture knobs

CROMOLUCIDO
POLISHED CHROME



CROMOSATINATO
SATIN CHROME



INOX BRASS
INOX BRASS



BRONZO TEND
BRONZE TEND



20/4

CROMOLUCIDO
POLISHED CHROME



CROMOSATINATO
SATIN CHROME



INOX BRASS
INOX BRASS



BRONZO TEND
BRONZE TEND



ASFOUR
CRYSTAL

Frascio

18/9

CROMO LUCIDO
POLISHED CHROME



CROMO SATINATO
SATIN CHROME



INOX BRASS
INOX BRASS



BRONZO TEND
BRONZE TEND



24/1

CROMO LUCIDO
POLISHED CHROME



CROMO SATINATO
SATIN CHROME



INOX BRASS
INOX BRASS



BRONZO TEND
BRONZE TEND



Frascio





ACCIAIO
STAINLESS STEEL

Straight

ACCIAIO/STAINLESS STEEL



Adrian e Jeremy Wright design



280/51 Q

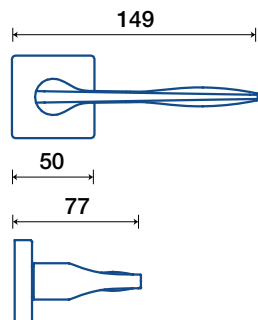

280/31 QDK

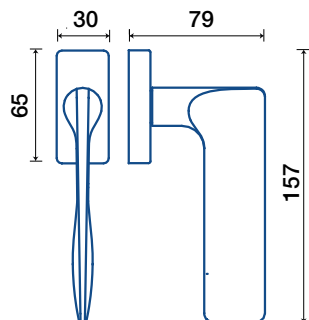

ACCIAIOLUCIDO
POLISHED STAINLESS STEEL



ACCIAIOSATINATO
SATIN STAINLESS STEEL



Kube

ACCIAIO SATINATO
SATIN STAINLESS STEEL

ACCIAIO/STAINLESS STEEL



Frascio design



290/51 Q

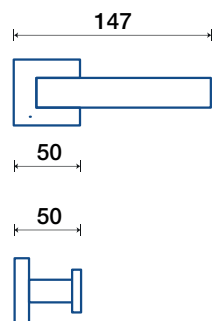

290/31 Q DK

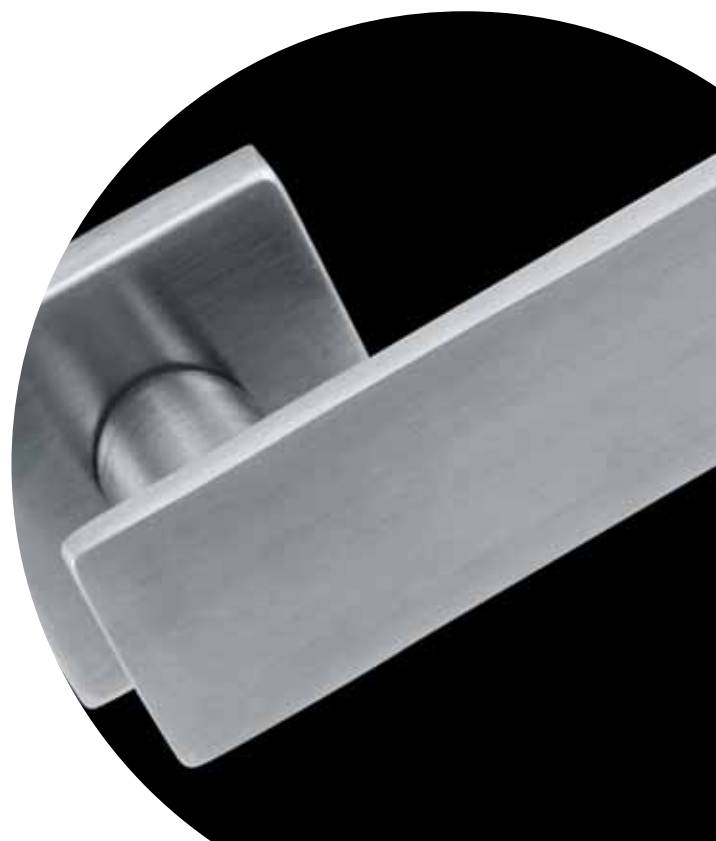
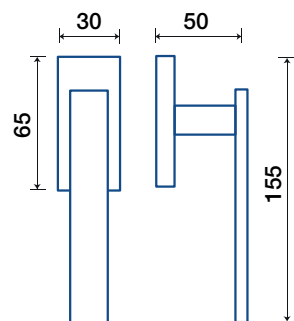

Alfa



Frascio design

ACCIAIO SATINATO
SATIN STAINLESS STEEL

ACCIAIO / STAINLESS STEEL



220/51 Q

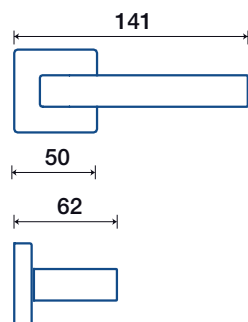

220/31 QDK

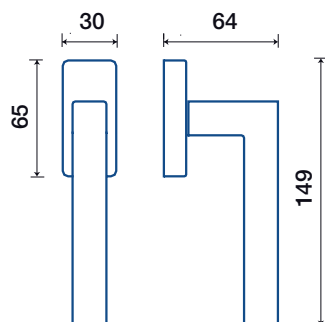

Beta



Frascio design

ACCIAIO SATINATO
SATIN STAINLESS STEEL

ACCIAIO/STAINLESS STEEL



230/51 Q

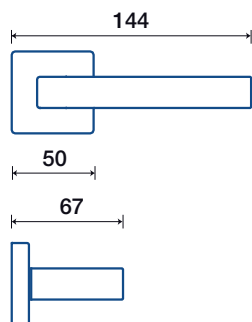

230/31 Q DK

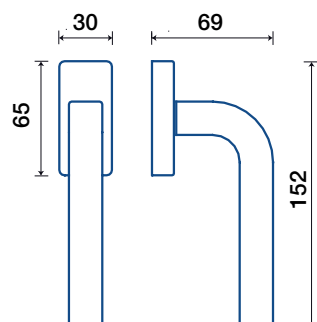

Christina

BICOLORE
BICOLORE

ACCIAIO/STAINLESS STEEL



Frascio design



5850/K 52

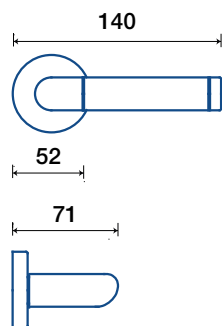

5850/32 DK

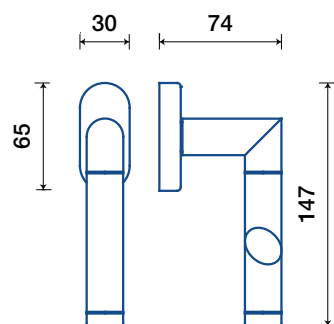

Loredana

BICOLORE
BICOLORE

ACCIAIO/STAINLESS STEEL



Frascio design



5700/K 52

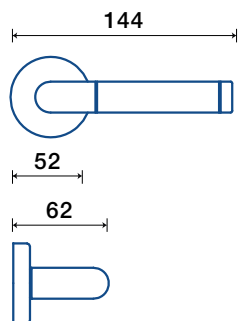

5700/32 DK

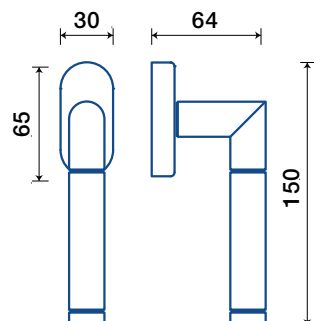

Loredana Square

ACCIAIO/STAINLESS STEEL



Frascio design



BICOLORE

BICOLORE



5700 51 Q

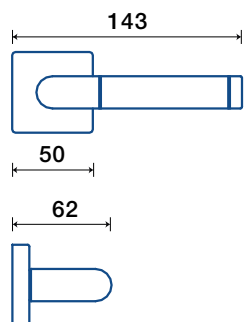

5700/31 QDK

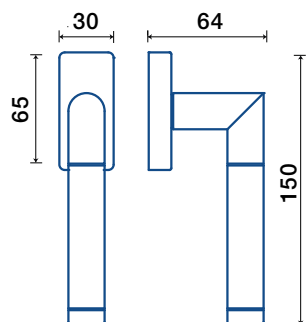

Adina

BICOLORE
BICOLORE

ACCIAIO/STAINLESS STEEL



Frascio design



5750/K 52

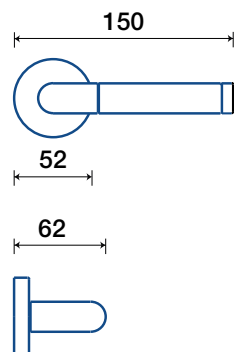

5750/32 DK

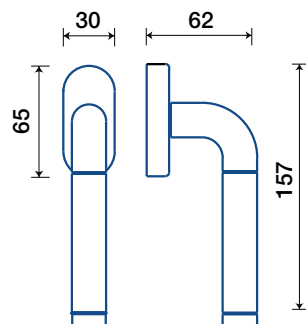

Alessia

ACCIAIO SATINATO
SATIN STAINLESS STEEL

ACCIAIO / STAINLESS STEEL



Frascio design



5000/K 52

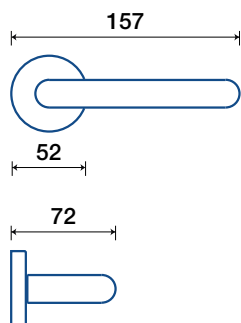

5000/32 DK

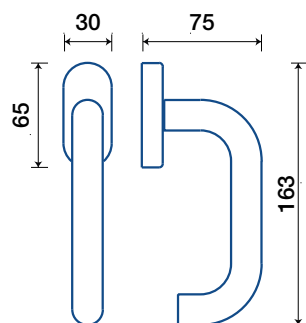

Frascio

Loft



Frascio design

ACCIAIO SATINATO
SATIN STAINLESS STEEL

ACCIAIO/STAINLESS STEEL



5200/K 52

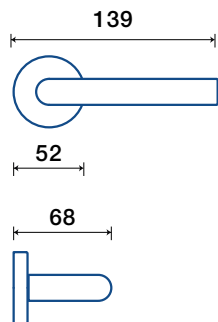

5200/32 DK

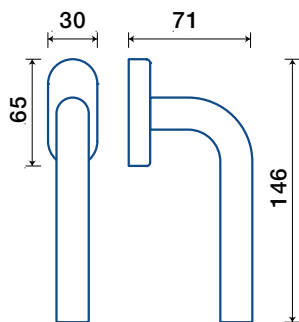

Lucia

ACCIAIO SATINATO
SATIN STAINLESS STEEL

ACCIAIO/STAINLESS STEEL



Frascio design



5100/K 52

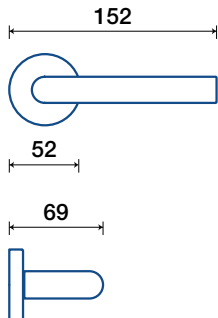

5100/32 DK

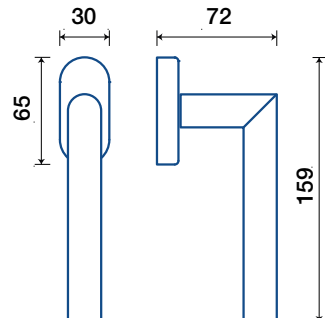

Lucia Square

ACCIAIO/STAINLESS STEEL



Frascio design



ACCIAIOSATINATO
SATIN STAINLESS STEEL



5100/51 Q

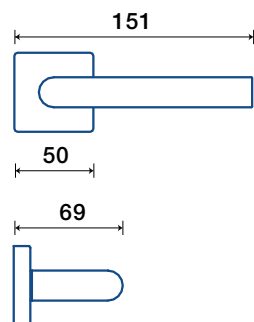

5100/31 QDK

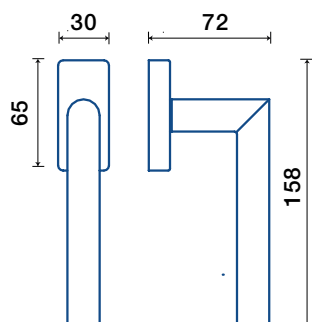





**THIN
THIN**

Rake QT

ALLUMINIO/ALUMINIUM



Giacomo Giustizieri design



920/50 QT

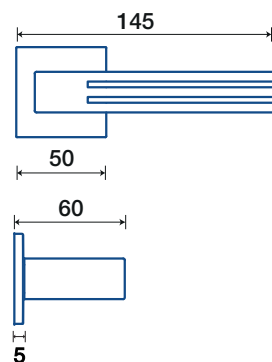

920/32 Q DK

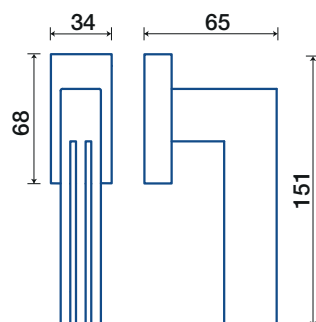

BIANCO
WHITE



NEFOOPACO
MATTBLACK



Opera2 RT

OTTONE/BRASS



Giulio Iacchetti design



307/50 RT

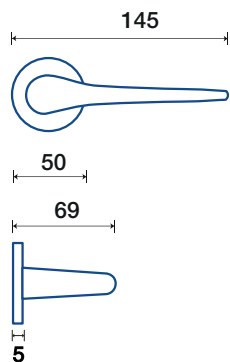

307/32 DK

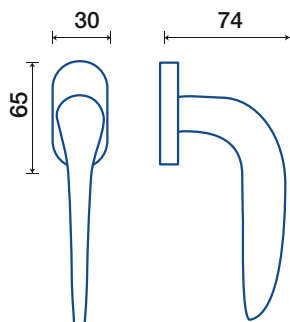

CROMOLUCIDO
POLISHED CHROME



CROMOSATINATO
SATIN CHROME



Blade QT



ZAMA/ZAMAK



Brian Sironi design



1500/50 QT

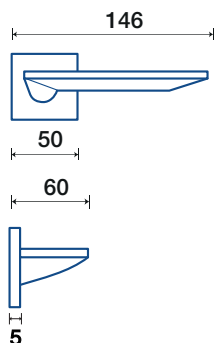

1500/32 QDK

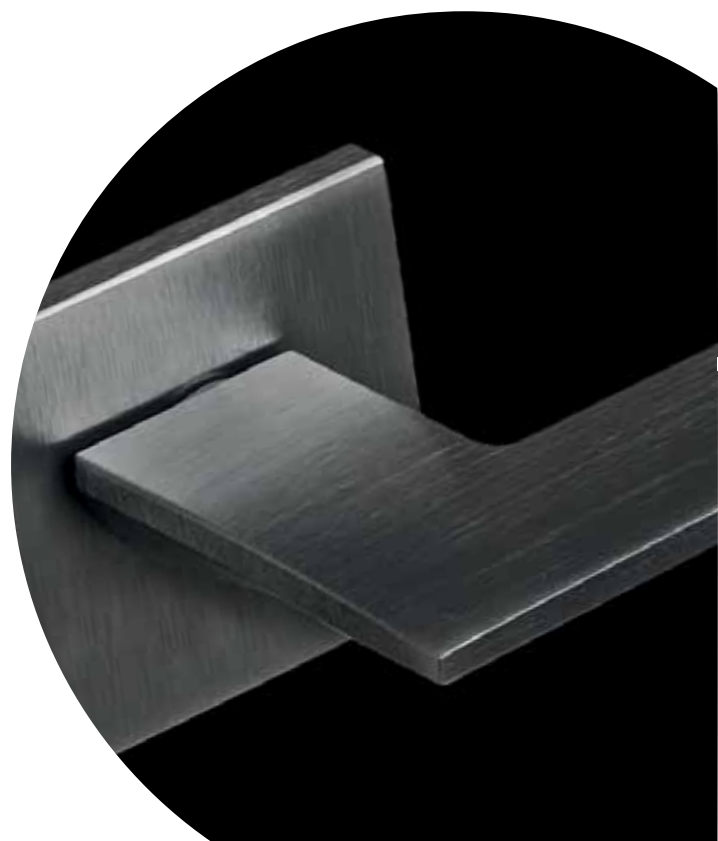
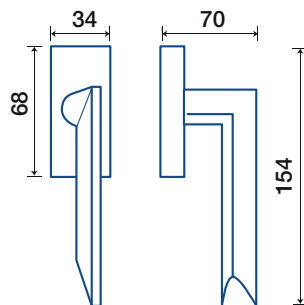

CROMOLUCIDO
POLISHED CHROME



CROMOSATINATO
SATIN CHROME



NICKEL SATINATO
SATIN NICKEL



ANTRACITE
ANTRACITE



Eidos QT



ZAMA/ZAMAK



Brian Sironi design



630/50 QT

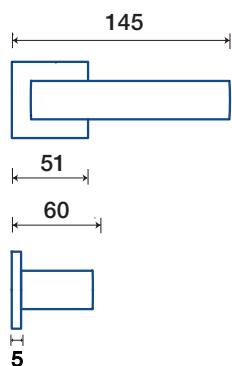

630/32 Q.DK

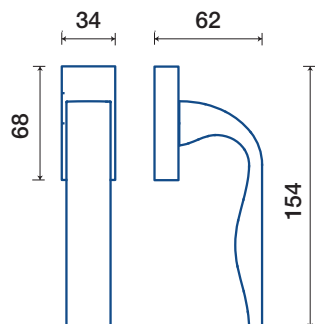

CROMOLUCIDO
POLISHED CHROME



CROMOSATINATO
SATIN CHROME



NICKEL SATINATO
SATIN NICKEL



ANTRACITE
ANTRACITE



Tuke QT



ZAMA/ZAMAK



Brian Sironi design



620/50 QT

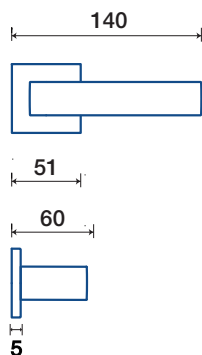

620/32 Q.DK

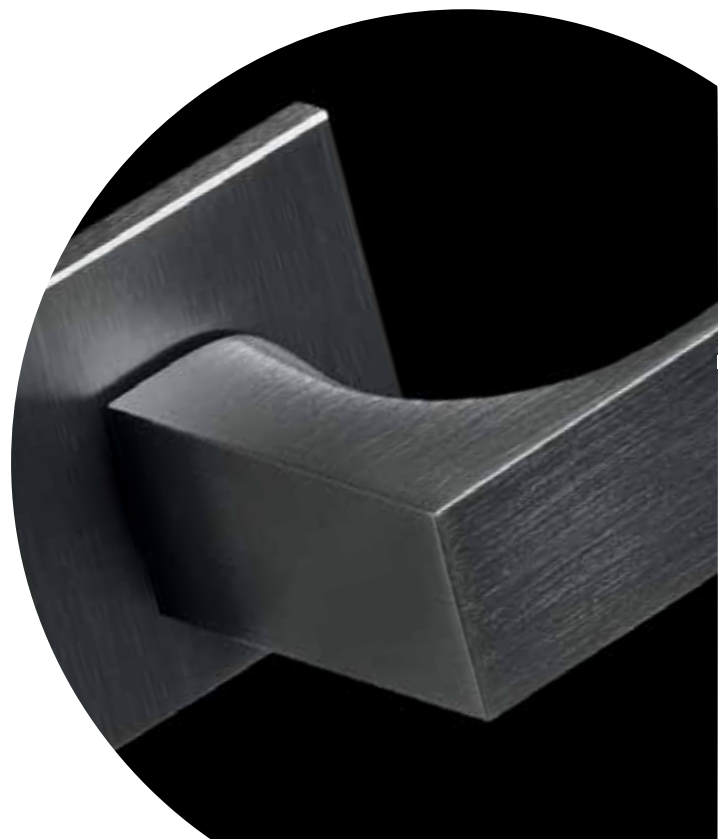
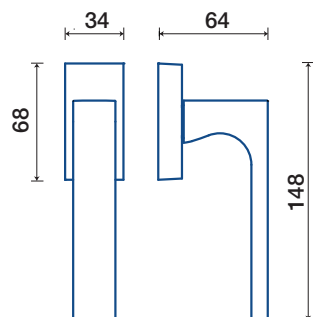

CROMOLUCIDO
POLISHED CHROME



CROMOSATINATO
SATIN CHROME



NICKEL SATINATO
SATIN NICKEL



ANTRACITE
ANTRACITE

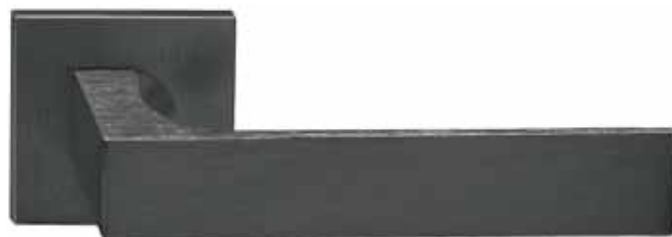

Jam QT



ZAMA/ZAMAK



Frascio design



639/50 QT

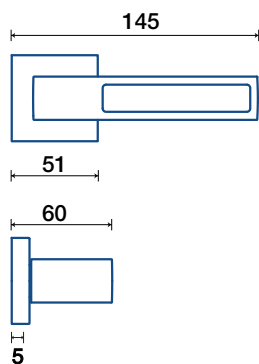

639/32 Q.DK

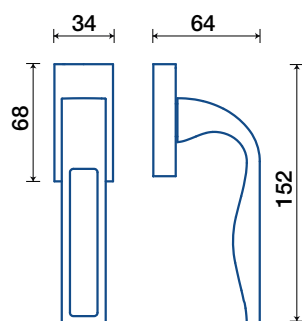

CROMOLUCIDO
POLISHED CHROME



CROMOSATINATO
SATIN CHROME



NICKEL SATINATO
SATIN NICKEL



ANTRACITE
ANTRACITE



Join QT



Giacomo Giustizieri design



925/50 QT

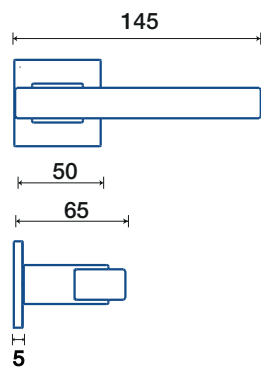

925/32 QDK

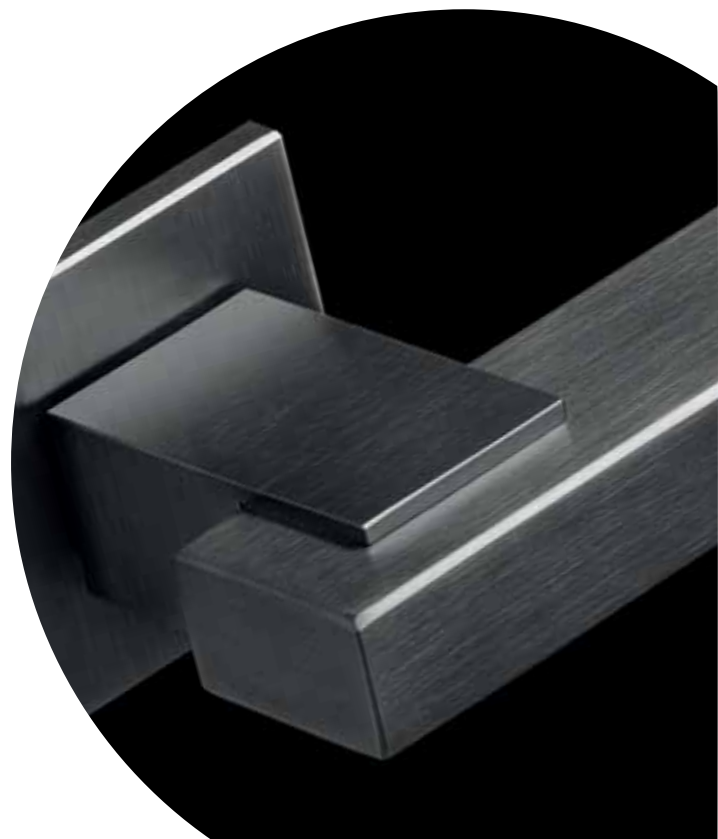
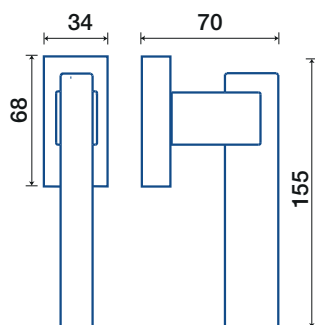

METAL

ACCIAIO SATINATO / CROMO LUCIDO
SATIN STAINLESS STEEL / POLISHED CHROME



ACCIAIO LUCIDO / CROMO SATINATO
POLISHED STAINLESS STEEL / SATIN CHROME

ANTRACITE
ANTRACITE



OTTONE / ACRILICO - BRASS / ACRYLIC

BLANCO / CROMO LUCIDO
BLANCO / POLISHED CHROME



BLANCO / CROMO SATINATO
BLANCO / SATIN CHROME

DAFNE / CROMO LUCIDO
DAFNE / POLISHED CHROME



DAFNE / CROMO SATINATO
DAFNE / SATIN CHROME

PEPPER / CROMO LUCIDO
PEPPER / POLISHED CHROME



PEPPER / CROMO SATINATO
PEPPER / SATIN CHROME

GHOST / CROMO LUCIDO
GHOST / POLISHED CHROME



GHOST / CROMO SATINATO
GHOST / SATIN CHROME

Ibis RT



OTTONE/BRASS



Giulio Iacchetti design



500/50 RT

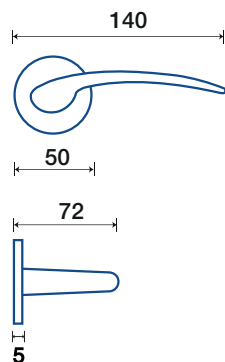

500/32 DK

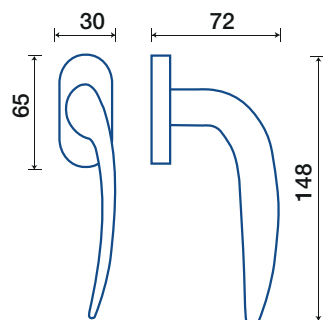

CROMO LUCIDO
POLISHED CHROME



CROMO SATINATO
SATIN CHROME



FED COPPER LUCIDO
FED COPPER POLISHED



FED COPPER SATINATO
FED COPPER SATIN



LONDON NIGHT LUCIDO
LONDON NIGHT POLISHED



LONDON NIGHT SATINATO
LONDON NIGHT SATIN



ANTRACITE
ANTRACITE



Pavone RT



OTTONE/BRASS



Controdesign design



505/50 RT

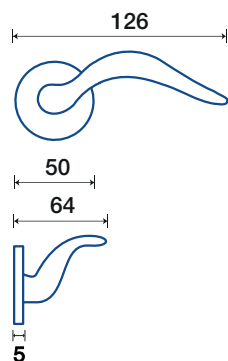

505/32 DK

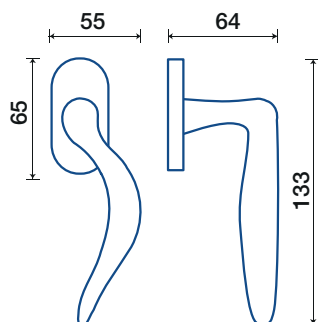

CROMOLUCIDO
POLISHED CHROME



CROMOSATINATO
SATIN CHROME



FED COPPER LUCIDO
FED COPPER POLISHED



FED COPPER SATINATO
FED COPPER SATIN



LONDON NIGHT LUCIDO
LONDON NIGHT POLISHED



LONDON NIGHT SATINATO
LONDON NIGHT SATIN



ANTRACITE
ANTRACITE



Fenice RT



OTTONE/BRASS



Marcello Ziliani design



503/50 RT

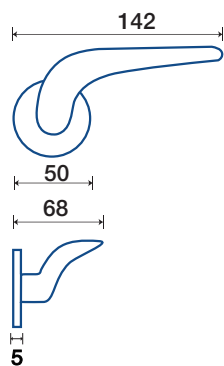

503/32 DK

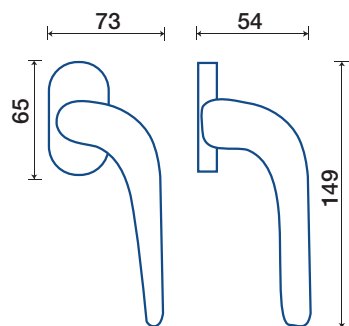

CROMO LUCIDO
POLISHED CHROME



CROMO SATINATO
SATIN CHROME



FED COPPER LUCIDO
FED COPPER POLISHED



FED COPPER SATINATO
FED COPPER SATIN



LONDON NIGHT LUCIDO
LONDON NIGHT POLISHED



LONDON NIGHT SATINATO
LONDON NIGHT SATIN



ANTRACITE
ANTRACITE



Filoo RT



ZAMA/ZAMAK

CD GL



CDGL design



1210/50 RT

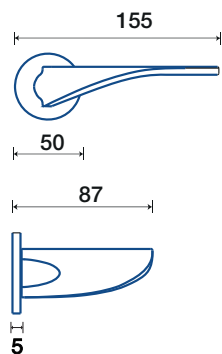

1210/32 DK

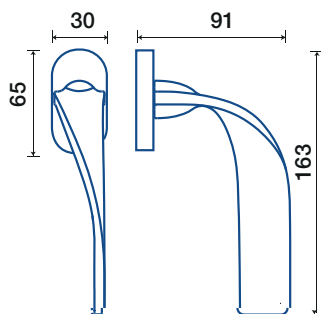

CROMO LUCIDO
POLISHED CHROME



CROMO SATINATO
SATIN CHROME



FED COPPER LUCIDO
FED COPPER POLISHED



FED COPPER SATINATO
FED COPPER SATIN



LONDON NIGHT LUCIDO
LONDON NIGHT POLISHED



LONDON NIGHT SATINATO
LONDON NIGHT SATIN



NICKEL SATINATO
SATIN NICKEL



ANTRACITE
ANTRACITE



Bump RT



ZAMA/ZAMAK



Brian Sironi design



1200/50 RT

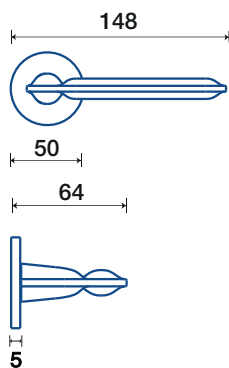

1200/32 DK

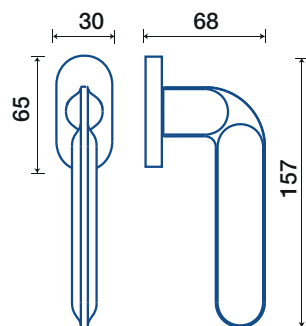

CROMOLUCIDO
POLISHED CHROME



CROMOSATINATO
SATIN CHROME



BRONZO TEND
BRONZE TEND



ANTRACITE
ANTRACITE



Duck RT



ZAMA/ZAMAK



Giulio Iacchetti design



1220/50 RT

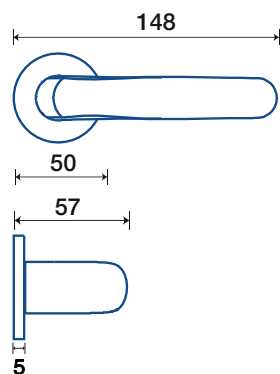

1220/32 DK

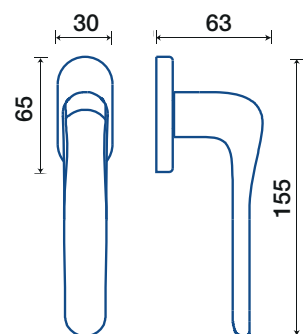

CROMOLUCIDO
POLISHED CHROME



CROMOSATINATO
SATIN CHROME



BRONZO TEND
BRONZE TEND



ANTRACITE
ANTRACITE



Kuma RT



ANTRACITE
ANTRACITE

OTTONE/BRASS



Brian Sironi design



640/50 RT

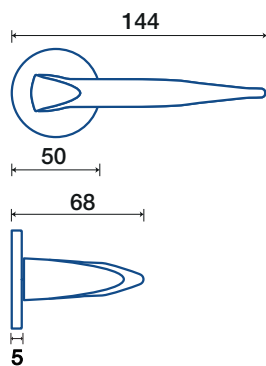

640/32 DK

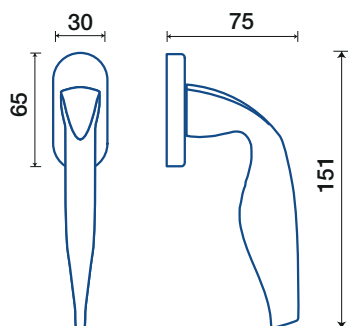

Kalè QT



ANTRACITE
ANTRACITE

ZAMA/ZAMAK



Frascio design



650/50 QT

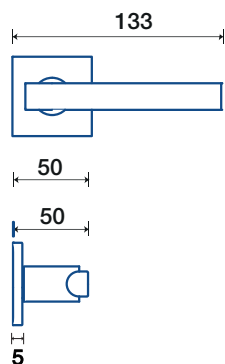

650/32 Q.DK

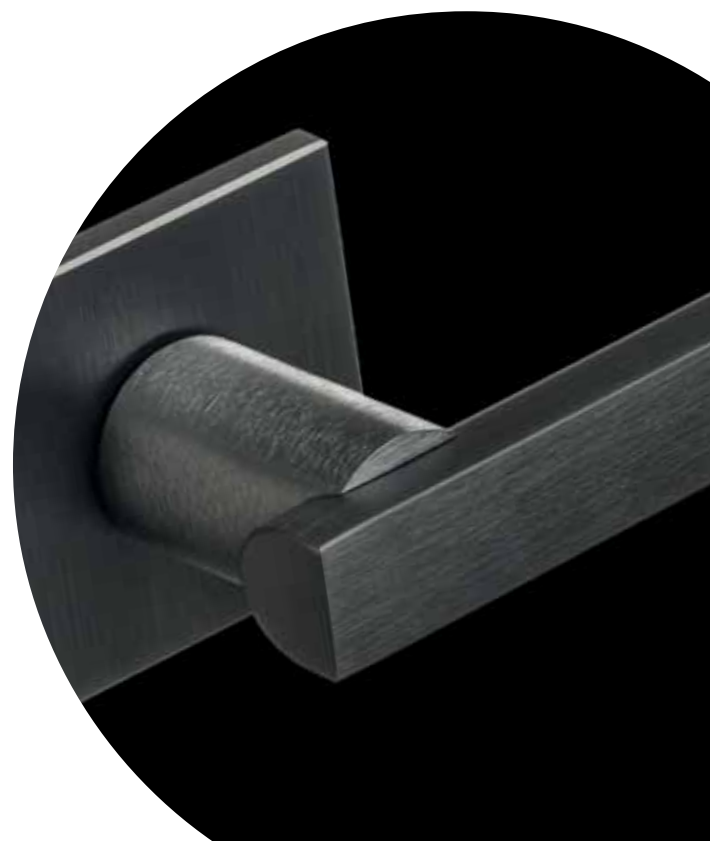
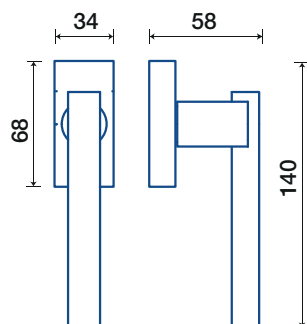

Sweep QT



OTTONE/BRASS

ANTRACITE

ANTRACITE



Roberto Semprini design



720/50 QT

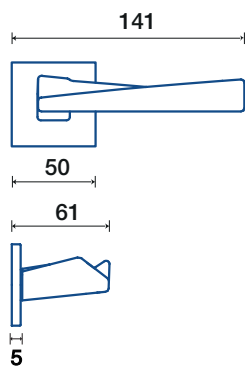

720/32 Q DK

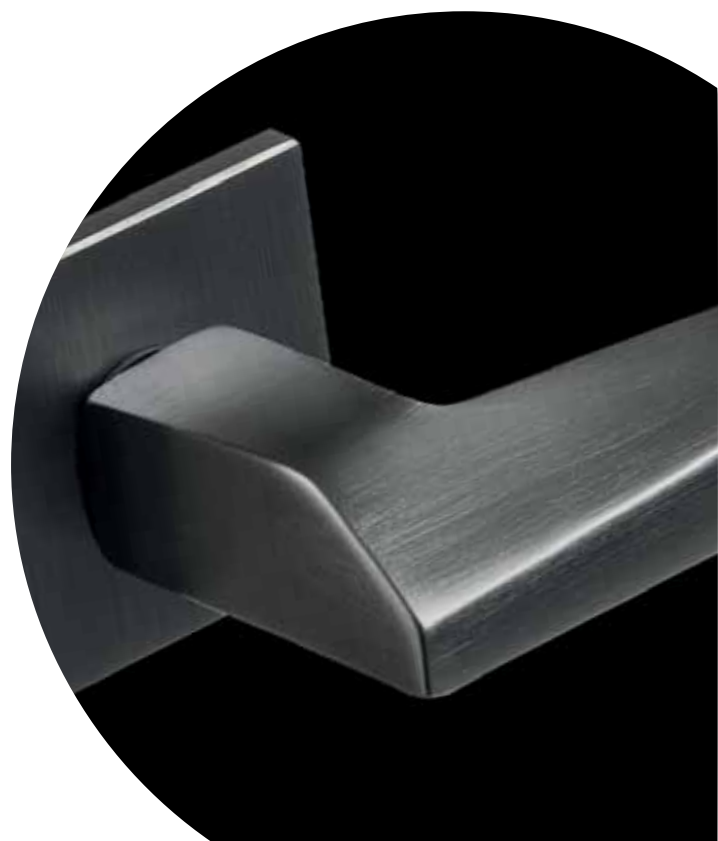
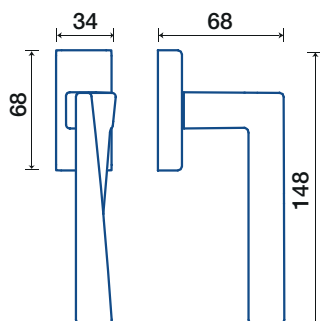

Uovo RT



ANTRACITE
ANTRACITE

OTTONE/BRASS



Frascio design



796/50 RT

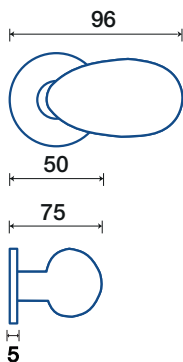

796/32 DK

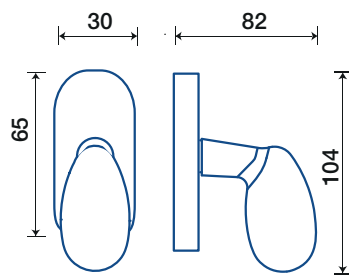

Leaf RT



ANTRACITE
ANTRACITE

ZAMA/ZAMAK



Brian Sironi design



1520/50 RT

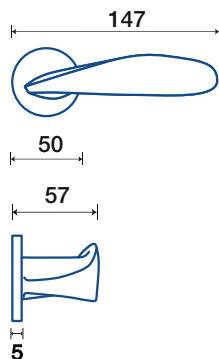

1520/32 DK

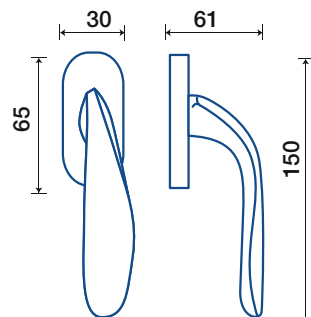



**TRADIZIONALI
TRADITIONAL**

Express

ZAMA/ZAMAK



Frascio design



860/51 Q

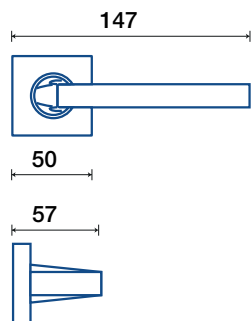

860/31 QDK

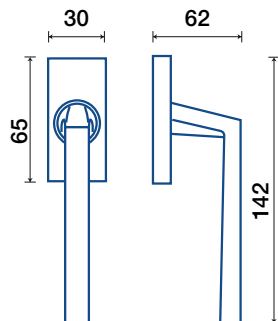

CROMOLUCIDO
POLISHED CHROME

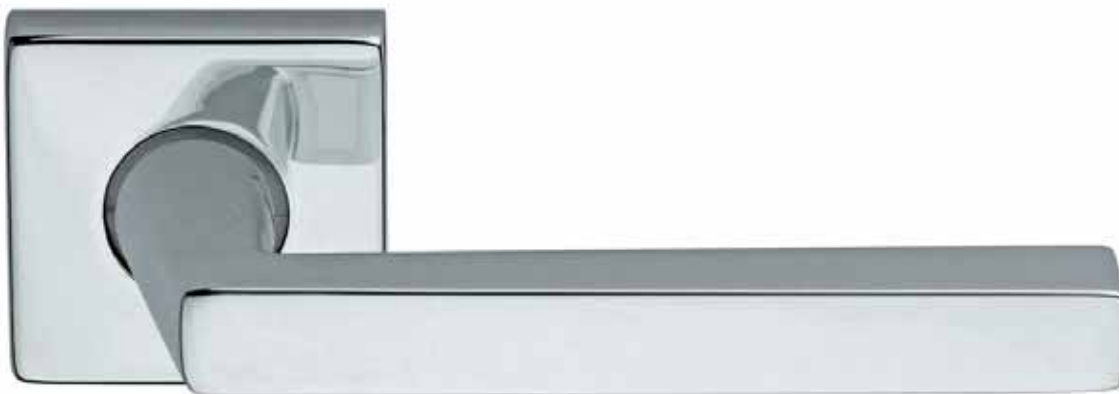

CROMOSATINATO
SATIN CHROME



Metro

ZAMA/ZAMAK



Frascio design



270/50 Q

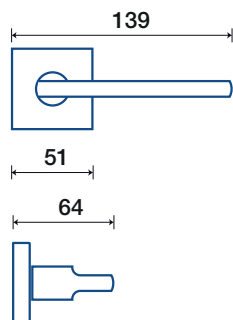

270/32 Q DK

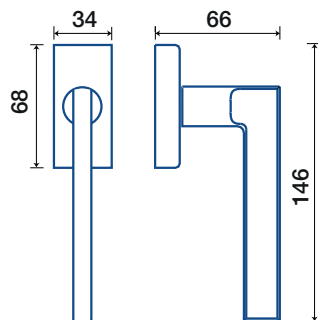

270/E 42

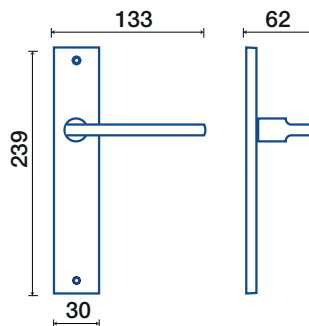

CROMOSATINATO

POLISHED CHROME



NICKEL SATINATO

SATIN NICKEL



Metro Round

ZAMA/ZAMAK



Frascio design



270/50 I

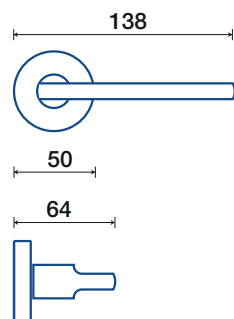

270/32 DK

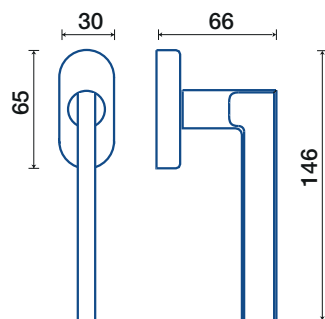

270/E 42

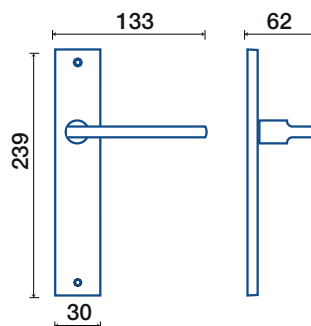

CROMOSATINATO

SATIN CHROME



NICKEL SATINATO

SATIN NICKEL



Aton

ZAMA/ZAMAK



Frascio design



930/50 I

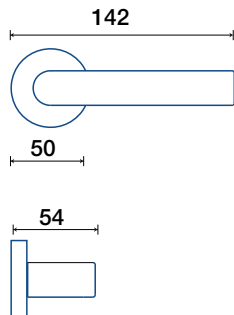

930/32 DK

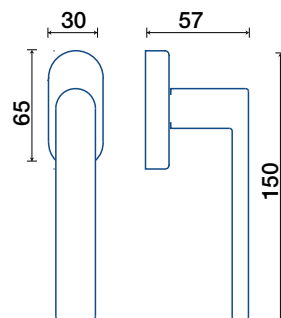

CROMOLUCIDO
POLISHED CHROME



CROMOSATINATO
SATIN CHROME



Butterfly



ZAMA/ZAMAK



Frascio design



250/45

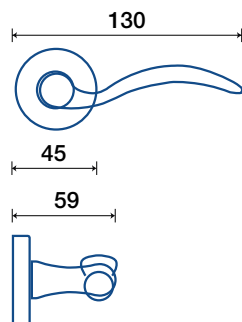

250/32 S DK

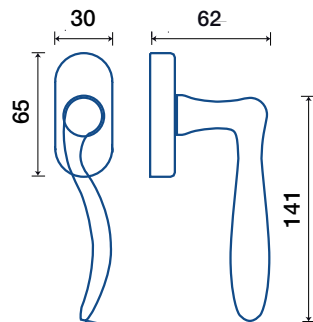

250/P 703

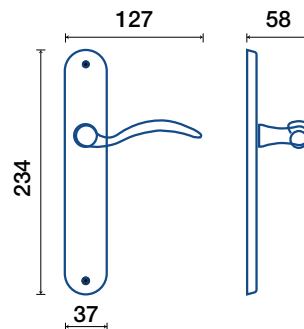

CROMOSATINATO

SATIN CHROME



INOX BRASS

INOX BRASS



Venere

OTTONE/BRASS



BCF design



309/50 I

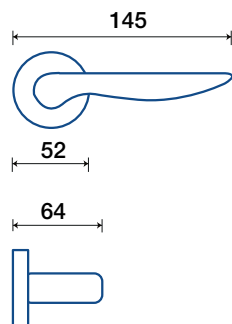

309/32 DK

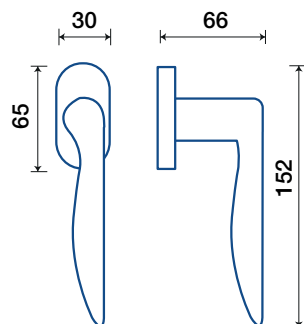

309/30

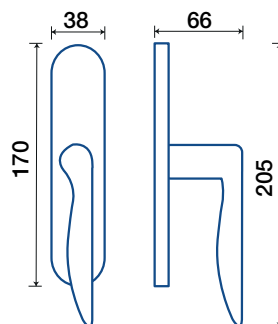

CROMOSATINATO

SATIN CHROME



OTTONE LUCIDO VERNICIATO

POLISHED BRASS



Soft



ZAMA/ZAMAK



BCF design



400/45

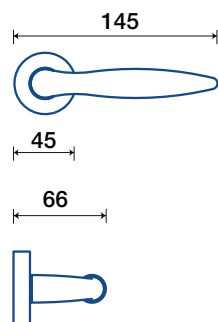

400/32 S DK

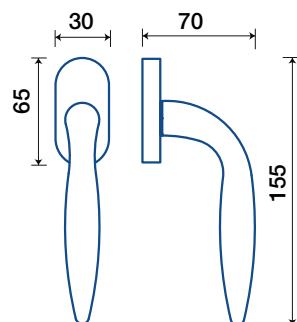

CROMOLUCIDO
POLISHED CHROME



CROMOSATINATO
SATIN CHROME



INOX BRASS
INOX BRASS



INOX CHROME
INOX CHROME



Soft Plus

ZAMA/ZAMAK



Frascio design



401/45

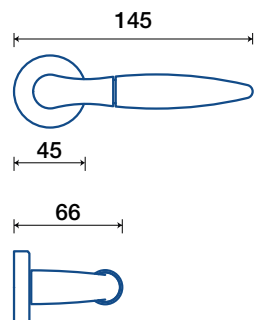

401/32 S DK

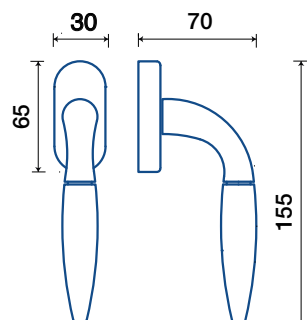

401/30

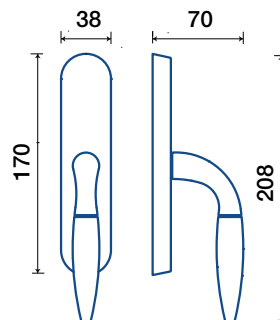

NICKEL SATINATO/ NICKEL
SATIN NICKEL/ NICKEL



BI-INOX
BI-INOX



Nicole



ZAMA/ZAMAK



BCF design



400/50 I

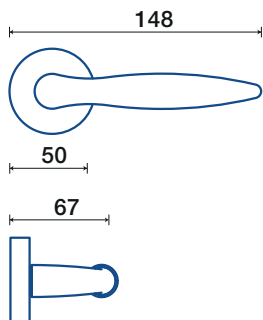

400/32 DK

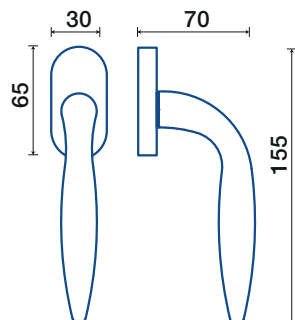

400/30

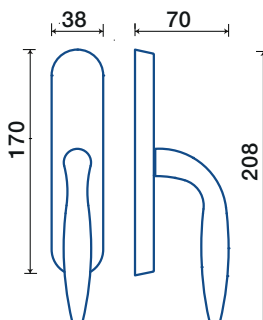

400/P 23

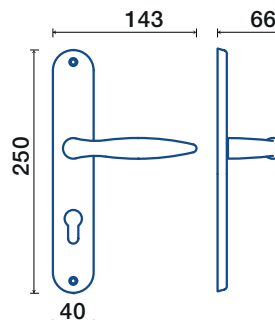

CROMOSATINATO

SATIN CHROME



ANTICOOPACO

MATT ANTIQUE BRASS



INOX BRASS

INOX BRASS



INOX CHROME

INOX CHROME



Nicole Plus

ZAMA/ZAMAK



Frascio design



401/50 I

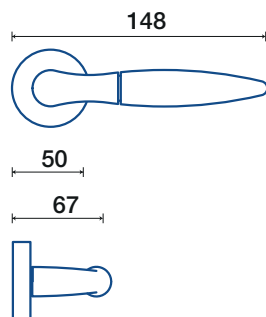

401/32 DK

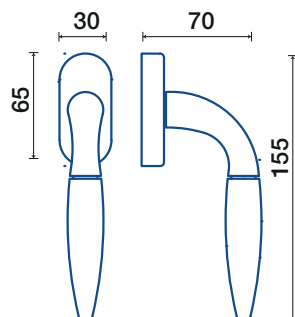

401/30

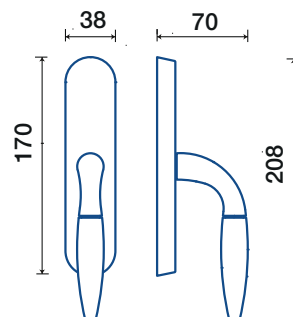

NICKEL SATINATO/ NICKEL
SATIN NICKEL/ NICKEL



BI-INOX
B-INOX



Laguna



OTTONE/BRASS



BCF design



300/50 I

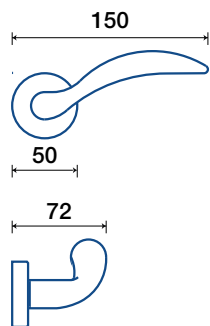

300/32 DK

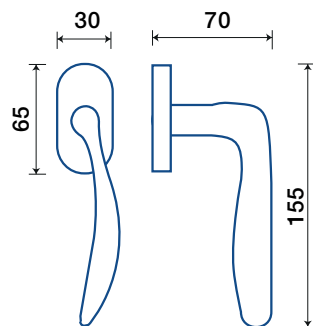

300/30

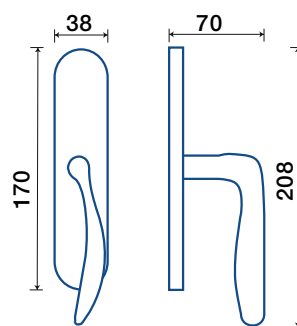

CROMOSATINATO

SATIN CHROME



ANTICOOPACO

MATT ANTIQUE BRASS



INOX BRASS

INOX BRASS



OTTONE LUCIDO VERNICIATO

POLISHED BRASS



Euro



OTTONE/BRASS



Frascio design



403/50 I

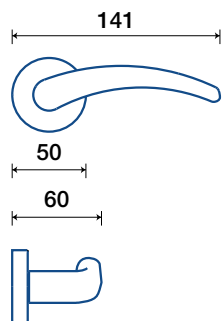

403/32 DK

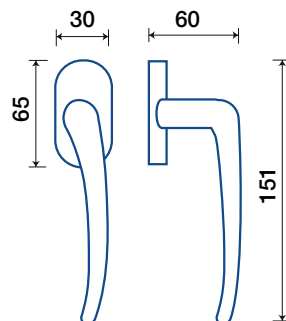

403/30

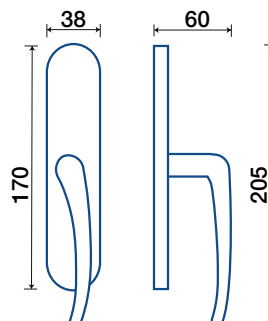

403/P 23

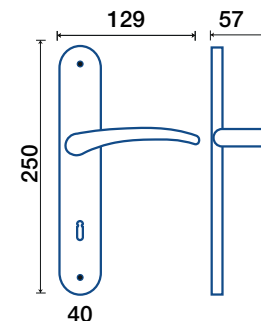

CROMOSATINATO
SATIN CHROME



ANTICOOPACO
MATT ANTIQUE BRASS



INOX BRASS
INOX BRASS



OTTONE LUCIDO VERNICIATO
POLISHED BRASS



Uovo



OTTONE/BRASS



Frascio design



796/50 I

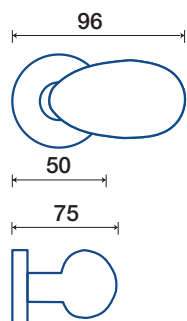

796/32 DK

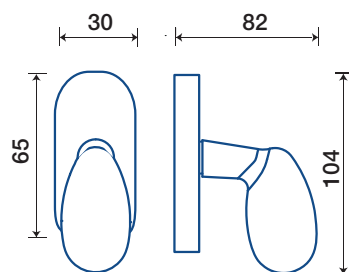

CROMO LUCIDO
POLISHED CHROME



CROMO SATINATO
SATIN CHROME



INOX BRASS
INOX BRASS



OTTONE LUCIDO VERNICIATO
POLISHED BRASS



Apollo

OTTONE/BRASS



Frascio design



110/50 R

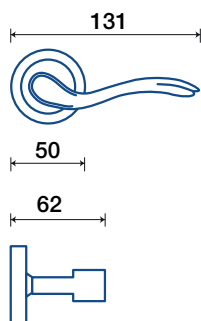

110/32 DK

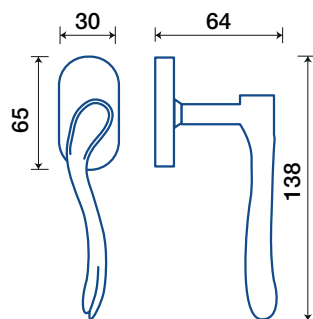

110/P 90

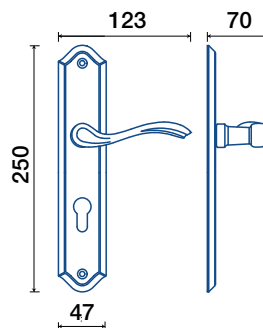

CROMOSATINATO
SATIN CHROME



ANTICATO
ANTICATO



BLACK IRON
BLACK IRON



OTTONE LUCIDO VERNICIATO
POLISHED BRASS



Star

OTTONE/BRASS



Frascio design



146/50 R

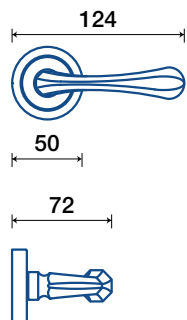

146/32 DK

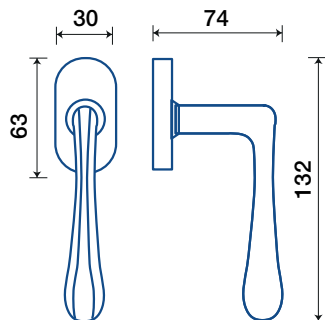

146/P 90

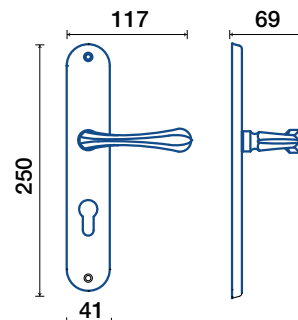

ANTICATO
ANTICATO



BLACKIRON
BLACKIRON



OTTONE LUCIDO VERNICIATO
POLISHED BRASS



Modulo L

OTTONE/BRASS



Frascio design



745/50 R

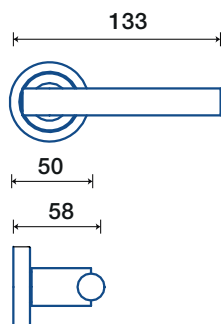

745/32 DK

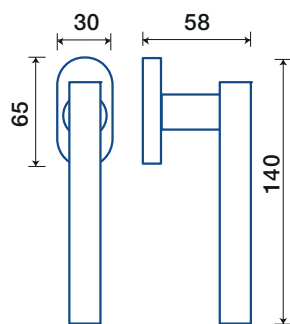

745/30

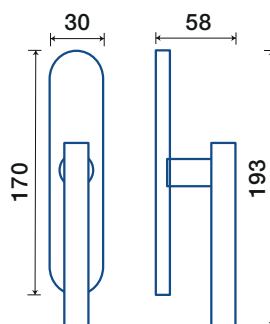

CROMOLUCIDO
POLISHED CHROME



CROMOSATINATO
SATIN CHROME



CROMOSATINATO/ CROMOLUCIDO
SATIN CHROME/ POLISHED CHROME



Easy



ZAMA/ZAMAK



Brian Sironi design



200/45

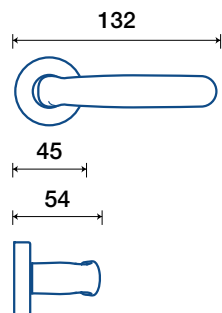

200/32 S DK

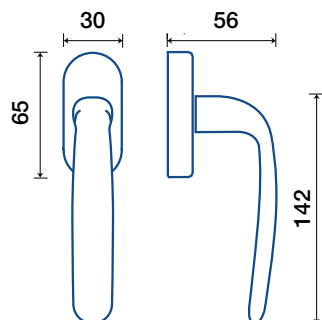

CROMOLUCIDO
POLISHED CHROME



CROMOSATINATO
SATIN CHROME



INOX BRASS
INOX BRASS



Halley

OTTONE/BRASS



BCF design



2250/50 R

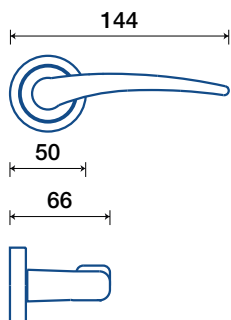

2250/32 DK

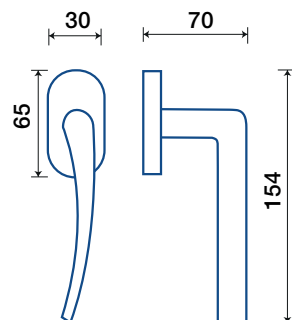

2250/30

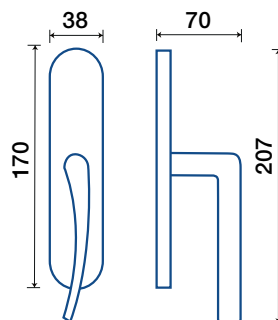

CROMOSATINATO
POLISHED CHROME



NICKEL SATINATO
SATIN NICKEL



OTTONE LUCIDO VERNICIATO
POLISHED BRASS



300/LP



OTTONE/BRASS



Frascio design

INOX BRASS - INOX BRASS
INOX CHROME - INOX CHROME
OTTONE LUCIDO VERNICIATO - POLISHED BRASS
CROMO SATINATO - SATIN CHROME



300/LP

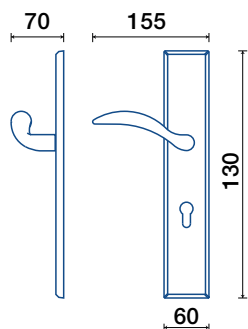

300/LE



OTTONE/BRASS



Frascio design

INOX BRASS - INOX BRASS
INOX CHROME - INOX CHROME
OTTONE LUCIDO VERNICIATO - POLISHED BRASS
CROMO SATINATO - SATIN CHROME



300/LE

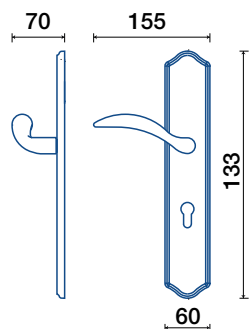

Raffaella

ZAMA/ZAMAK



Frascio design

PERLA / CROMO LUCIDO
PEARL / POLISHED CHROME



5350/50 R

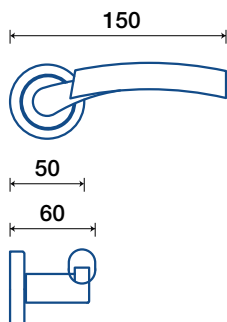

5350/32 DK

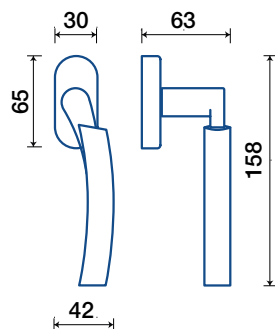

Laura

ZAMA/ZAMAK

PERLA / CROMO LUCIDO
PEARL / POLISHED CHROME



Frascio design



5550/50 R

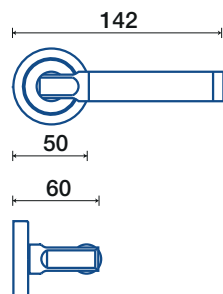

5550/32 DK

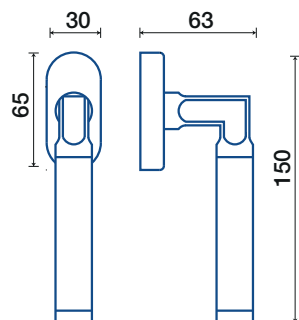

Frascio

Mimosa

CERAMICA BIANCA / OTTONE LUCIDO VERNICIATO
WHITE CERAMIC / POLISHED BRASS

OTTONE / CERAMICA - BRASS / CERAMIC



Frascio design



192/45

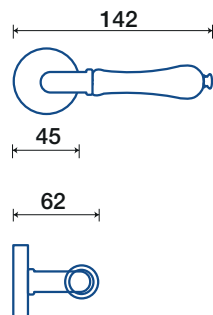

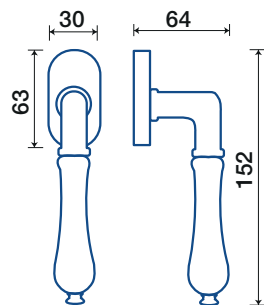

192/32 S DK

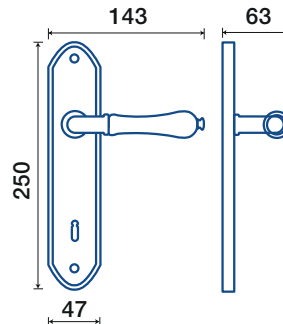

192/P 90

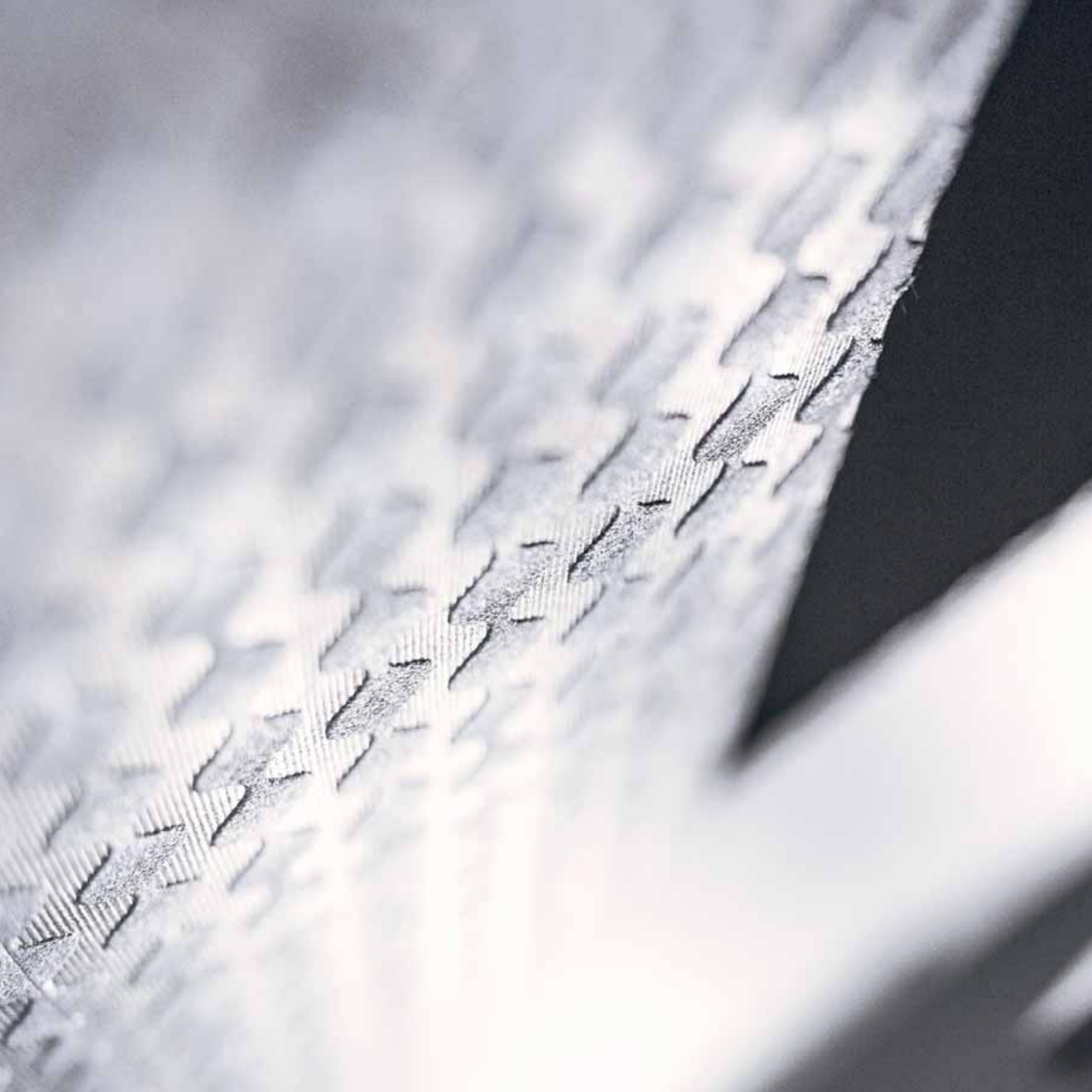



A close-up, black and white photograph of a sliding door track. The track is a dark, metallic profile with a textured surface. A handle, likely made of metal or a composite material, is mounted on the track. The handle has a curved, ergonomic shape. The background is dark and out of focus, emphasizing the track and handle.

**KIT PORTE SCORREVOLI,
POMOLI E ACCESSORI
SLIDING DOOR HANDLES,
PULL HANDLES E ACCESSORIES**

A Coppia nicchie tonde con o senza foro chiave



COPPIA NICCHIE TONDE
CON O SENZA FORO CHIAVE,
SENZA SERRATURA,
SENZA MANIGLIETTA DI
TRASCINAMENTO

SLIDING DOOR HANDLE BLIND OR
KEY HOLE, WITHOUT LOCK AND
FINGER FULL

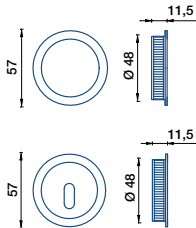

FINITURE/FINISHES

OTTONE LUCIDO VERNICIATO
POLISHED BRASS
CROMO LUCIDO
POLISHED CHROME
CROMO SATINATO
SATIN CHROME
BRONZO
BRONZE
BIANCO
WHITE
LONDON NIGHT LUCIDO
LONDON NIGHT POLISHED
LONDON NIGHT SATINATO
LONDON NIGHT SATIN
RED COPPER LUCIDO
RED COPPER POLISHED
RED COPPER SATINATO
RED COPPER SATIN
GREY STONE
GREY STONE
ANTRACITE
ANTRACITE

B Kit n° 0 con foro chiave

KIT CON CHIAVE SNO DATA,
SERRATURA ENTRATA 50mm
E MANIGLIETTA
DI TRASCINAMENTO

SLIDING DOOR HANDLE WITH
FLEXIBLE KEY, LOCK 50mm EKS
AND FINGER FULL

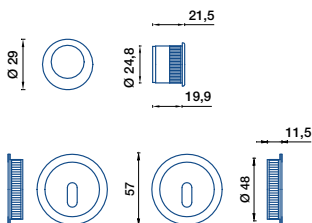

C Kit n° 7

KIT SENZA FORO CHIAVE, SENZA
SEFFRATURA, CON MANIGLIETTA
DI TRASCINAMENTO

BLIND SLIDING DOOR HANDLE
WITHOUT LOCK, WITH FINGER PULL

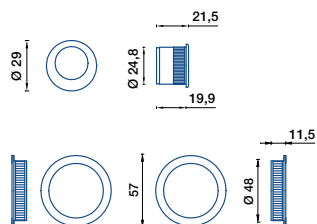

FINITURE/FINISHES

OTTONE LUCIDO VERNICIATO
POLISHED BRASS
CROMO LUCIDO
POLISHED CHROME
CROMO SATINATO
SATIN CHROME
BRONZO
BRONZE
BIANCO
WHITE
LONDON NIGHT LUCIDO
LONDON NIGHT POLISHED
LONDON NIGHT SATINATO
LONDON NIGHT SATIN
RED COPPER LUCIDO
RED COPPER POLISHED
RED COPPER SATINATO
RED COPPER SATIN
GREY STONE
GREY STONE
ANTRACITE
ANTRACITE

E Kit n° 0

KIT A SCOMPARSITA' TOTALE CON
SEFFRATURA ENTRATA
50 mm E MANIGLIETTA
DI TRASCINAMENTO

SLIDING DOOR HANDLE WITH LOCK
50 mm BKS AND FINGER PULL

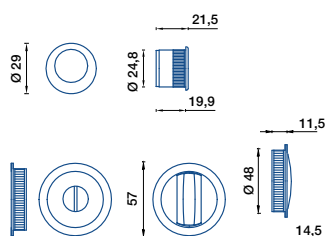

D Coppia nicchie tonde alte

COPPIA NICCHIE TONDE ALTE
SENZA FORO CHIAVE E SENZA
SERRATURA

BLIND SLIDING DOOR HANDLE
WITHOUT LOCK

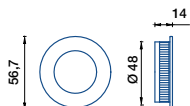

O-MT 48

DOPPIO ANELLO SENZA
SERRATURA

SLIDING DOOR HANDLE WITH
DOUBLE RING TURN W/OUT LOCK

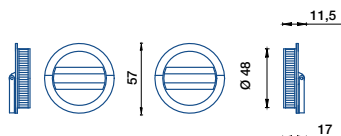

FINITURE/FINISHES

OTTONE LUCIDO VERNICIATO

POLISHED BRASS

CROMO LUCIDO

POLISHED CHROME

CROMO SATINATO

SATIN CHROME

BRONZO

BRONZE

P-MM 48

ANELLO + VITE SENZA
SERRATURA

SLIDING DOOR HANDLE WITH
RING AND RELEASE W/OUT LOCK

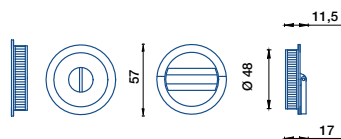

F Kit n° 1

KIT A SCOMPARSA TOTALE CON
SERRATURA ENTRATA 50 mm E
MANIGLIETTA DI TRASCINAMENTO

SLIDING DOOR HANDLE WITH LOCK
50 mm BKS AND FINGERPULL

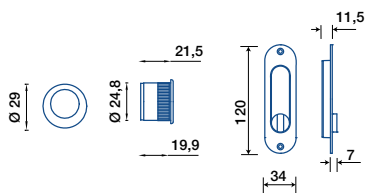

H Kit n° 3

KIT CON CHIAVE SNODATA CON
SERRATURA ENTRATA 50 mm E
MANIGLIETTA DI TRASCINAMENTO

SLIDING DOOR HANDLE WITH FLEXIBLE
KEY, LOCK 50 mm BKS
AND FINGERPULL

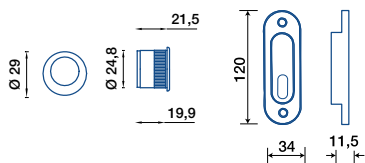

FINITURE/FINISHES

OTTONE LUCIDO VERNICIATO

POLISHED BRASS

CROMO LUCIDO

POLISHED CHROME

CROMO SATINATO

SATIN CHROME

BRONZO

BRONZE

I Kit n° 4

KIT SENZA FORO CHIAVE, SENZA
SERRATURA, CON MANIGLIETTA
DI TRASCINAMENTO

BLIND SLIDING DOOR HANDLE,
WITH FINGERPULL

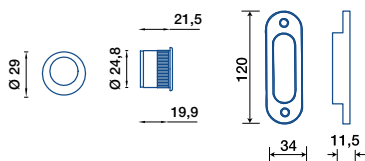

R Kit quadrato con foro chiave

**KIT QUADRATO CON CHIAVE
SNODATA, CON SEPPATURA
ENTRATA 50mm E MANIGLIETTA
DI TRASCINAMENTO**

**SLIDING DOOR HANDLE WITH
FLEXIBLE KEY, LOCK 50 mm BKS
AND FINGER PULL**

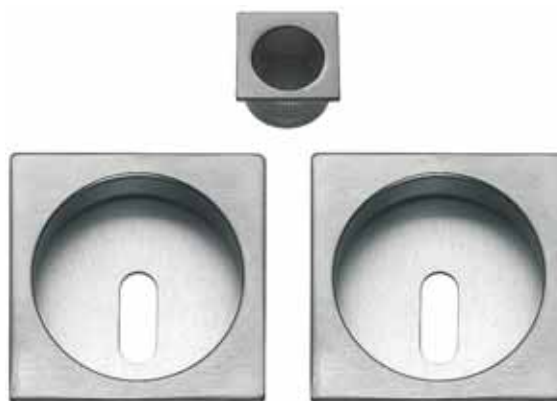
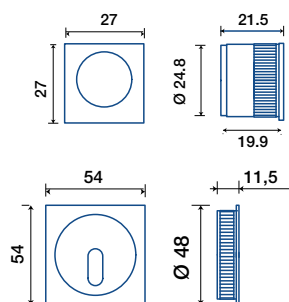

FINITURE/FINISHES

OTTONE LUCIDO VERNICIATO
POLISHED BRASS
CROMO LUCIDO
POLISHED CHROME
CROMO SATINATO
SATIN CHROME
BRONZO TREND
BRONZE TREND
BIANCO
WHITE
LONDON NIGHT LUCIDO
LONDON NIGHT POLISHED
LONDON NIGHT SATINATO
LONDON NIGHT SATIN
RED COPPER LUCIDO
RED COPPER POLISHED
RED COPPER SATINATO
RED COPPER SATIN
GREY STONE
GREY STONE
ANTRACITE
ANTRACITE
NERO OPAO
MATT BLACK
CORTEN
CORTEN
CRACKLÉ
CRACKLÉ
LEATHER
LEATHER
OSSIDATO
OSSIDATO

S Kit n° 8 quadrato

**KIT QUADRATO SENZA FORO
CHIAVE, SENZA SEPPATURA,
CON MANIGLIETTA DI
TRASCINAMENTO**

**BLIND SLIDING DOOR HANDLE
WITHOUT LOCK, WITH FINGER PULL**

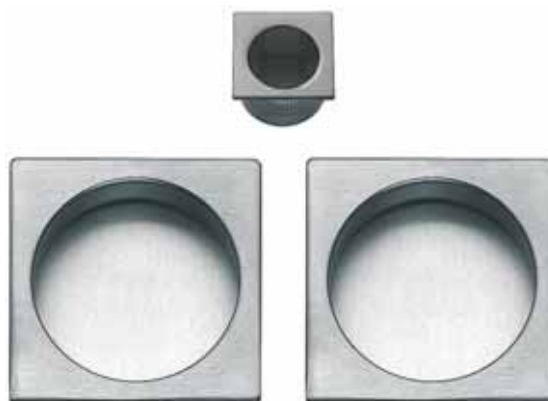
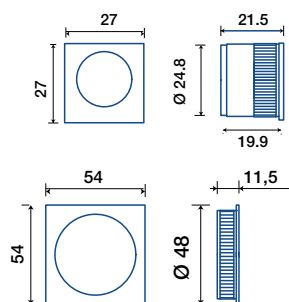

Q Coppia nicchie quadrate con o senza foro

**COPPIA NICCHIE QUADRATE
CON O SENZA FORO CHIAVE,
SENZA SEFFATURA,
SENZA MANIGLIETTA DI
TRASCINAMENTO**

**SLIDING DOOR HANDLE BLIND OR
KEY HOLE WITHOUT LOCK AND
FINGER FULL**

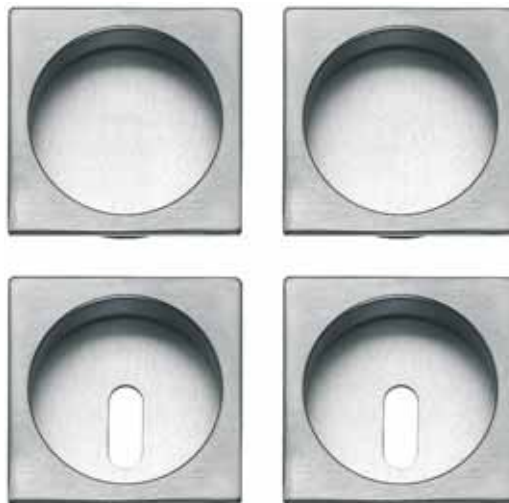
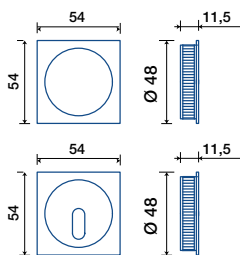

FINITURE/FINISHES

OTTONE LUCIDO VERNICIATO
POLISHED BRASS
CROMO LUCIDO
POLISHED CHROME
CROMO SATINATO
SATIN CHROME
BRONZO TREND
BRONZE TREND
BIANCO
WHITE
LONDON NIGHT LUCIDO
LONDON NIGHT POLISHED
LONDON NIGHT SATINATO
LONDON NIGHT SATIN
RED COPPER LUCIDO
RED COPPER POLISHED
RED COPPER SATINATO
RED COPPER SATIN
GREY STONE
GREY STONE
ANTRACITE
ANTRACITE
NERO OPACO
MATT BLACK
BIANCO
WHITE
CORTEN
CORTEN
CRACKLÉ
CRACKLÉ
LEATHER
LEATHER
OSSIDATO
OSSIDATO

T Kit n° 9 quadrato

**KIT QUADRATO A SCOMPARSA
TOTALE CON SEFFATURA
ENTRATA 50mm E MANIGLIETTA
DI TRASCINAMENTO**

**SLIDING DOOR HANDLE WITH LOCK
50 mm BKS AND FINGER FULL**

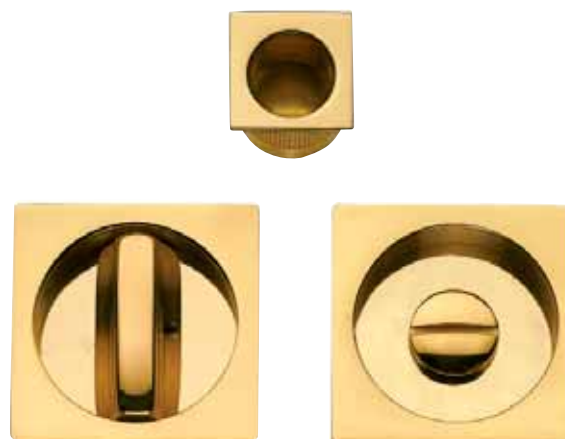
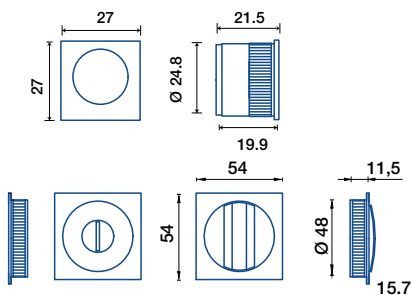

Coppia nicchie con mezzaluna

AA



COPPIA NICCHIE TONDE
CON MEZZALUNA

ROUND SLIDING DOOR HANDLE
WITH HALF MOON

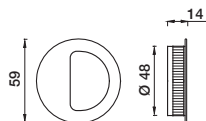

QB



COPPIA NICCHIE QUADRATE
CON MEZZALUNA

SQUARE SLIDING DOOR HANDLE
WITH HALF MOON

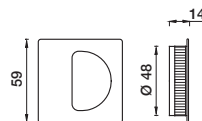

FINITURE/FINISHES

OTTONE LUCIDO VERNICIATO
POLISHED BRASS
CROMO LUCIDO
POLISHED CHROME
CROMO SATINATO
SATIN CHROME

L



MANIGLIETTA DI
TRASCINAMENTO TONDA

ROUND FINGER FULL

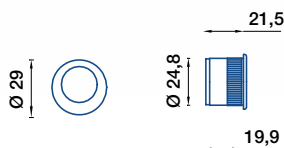

V



MANIGLIETTA DI
TRASCINAMENTO QUADRATA

SQUARE FINGER FULL

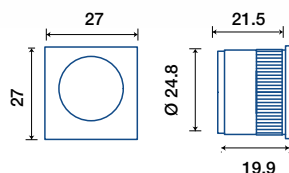

FINITURE/FINISHES

OTTONE LUCIDO VERNICIATO
POLISHED BRASS
CROMO LUCIDO
POLISHED CHROME
CROMO SATINATO
SATIN CHROME
BRONZO
BRONZE
BIANCO
WHITE
LONDON NIGHT LUCIDO
LONDON NIGHT POLISHED
LONDON NIGHT SATINATO
LONDON NIGHT SATIN
RED COPPER LUCIDO
RED COPPER POLISHED
RED COPPER SATINATO
RED COPPER SATIN
GREY STONE
GREY STONE
ANTRACITE
ANTRACITE

Serratura per porte scorrevoli

SERRATURA PORTE SCORREVOLI
CON QUADRO, ENTRATA 50 mm,
FRONTALE 16 mm

SLIDING DOOR LOCK
WITH SQUARE HOLE,
50 mm BKS, 16 mm FACEPLATE

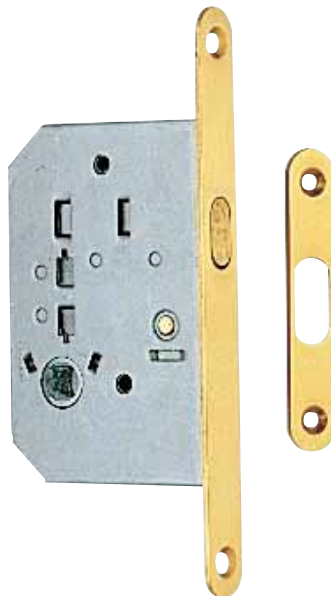

FINITURE/FINISHES

OTTONE LUCIDO VERNICIATO
POLISHED BRASS
CROMO LUCIDO
POLISHED CHROME
CROMO SATINATO
SATIN CHROME
BRONZO
BRONZE

Serratura per porte scorrevoli con chiave snodata

SERRATURA PORTE SCORREVOLI
CON CHIAVE SNODATA, ENTRATA
50 mm, FRONTALE 16 mm

SLIDING DOOR LOCK WITH KEY
HOLE, 50 mm BKS, 16 mm
FACEPLATE

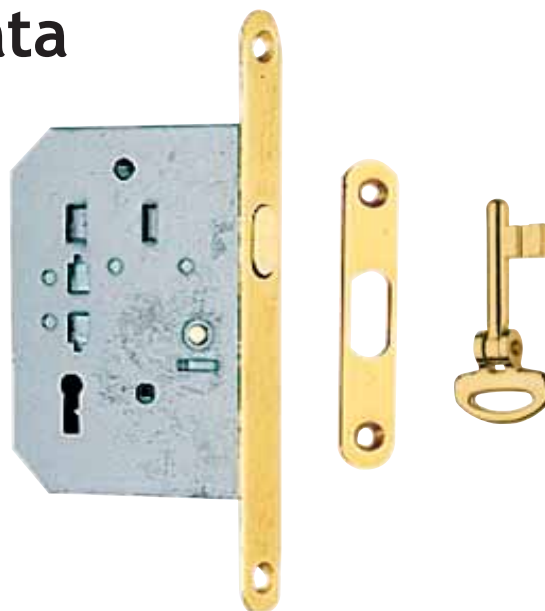

Frontale gaccia

FRONTALE GACCIA CON
O SENZA FORO

FRONT GACCIA WITH OR
WITHOUT HOLE

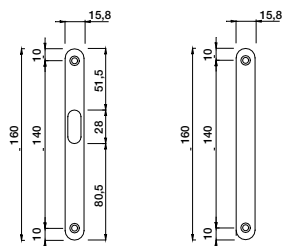

FINITURE/FINISHES

OTTONE LUCIDO VERNICIATO
POLISHED BRASS
CROMO LUCIDO
POLISHED CHROME
CROMO SATINATO
SATIN CHROME
BRONZO
BRONZE

Nicchia 981

NICCHIA CON O SENZA FORO
CHIAVE

SLIDING DOOR HANDLE WITH OR
WITHOUT KEY HOLE

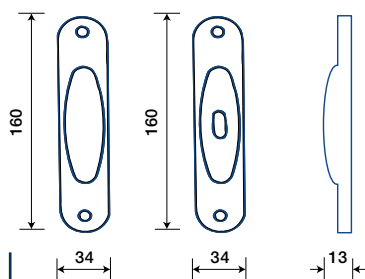

FINITURE/FINISHES

OTTONE LUCIDO VERNICIATO
POLISHED BRASS
CROMO LUCIDO
POLISHED CHROME
CROMO SATINATO
SATIN CHROME

Nicchia 800

NICCHIA CON O SENZA FORO
CHIAVE

SLIDING DOOR HANDLE WITH OR
WITHOUT KEY HOLE

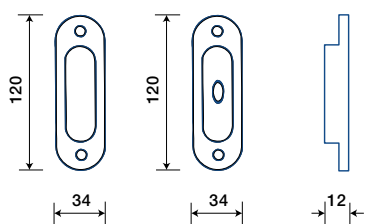

FINITURE/FINISHES

OTTONE LUCIDO VERNICIATO
POLISHED BRASS
CROMO LUCIDO
POLISHED CHROME
CROMO SATINATO
SATIN CHROME

Nicchia 780

NICCHIA CON O SENZA FORO
CHIAVE

SLIDING DOOR HANDLE WITH OR
WITHOUT KEY HOLE

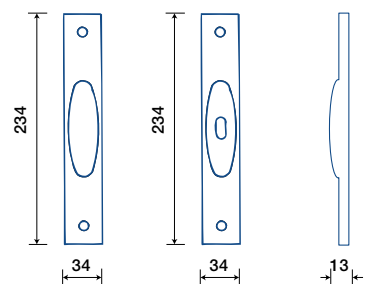

FINITURE/FINISHES

OTTONE LUCIDO VERNICIATO
POLISHED BRASS
CROMO LUCIDO
POLISHED CHROME
CROMO SATINATO
SATIN CHROME

Siena



OTTONE/BRASS

FINITURE/FINISHES

CROMO SATINATO
SATIN CHROME
NICKEL SATINATO
SATIN NICKEL
ANTRACITE
ANTRACITE

5041

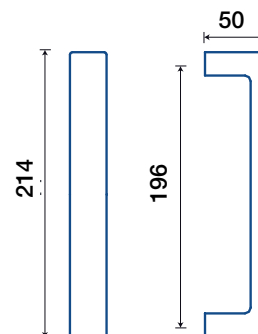

5041 UG

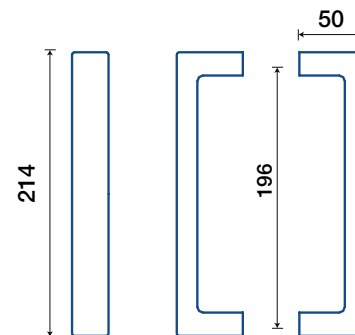

Frascio design



Tuke Glass



Brian Sironi design



OTTONE/BRASS

FINITURE/FINISHES

CROMO LUCIDO
POLISHED CHROME
CROMO SATINATO
SATIN CHROME

629

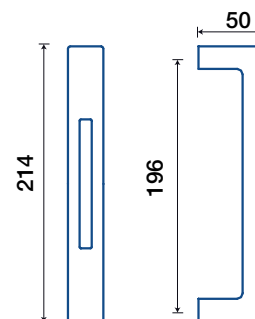

629 UG

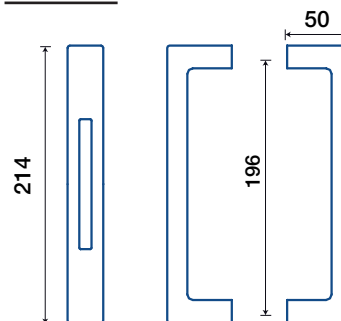

Pisa



OTTONE/BRASS

FINITURE/FINISHES

INOX BRASS
INOX BRASS
CROMO LUCIDO
POLISHED CHROME
CROMO SATINATO
SATIN CHROME

5042

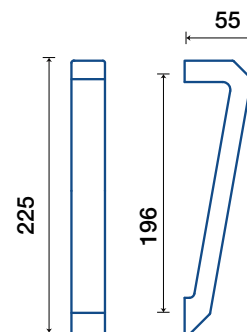

5042 UG

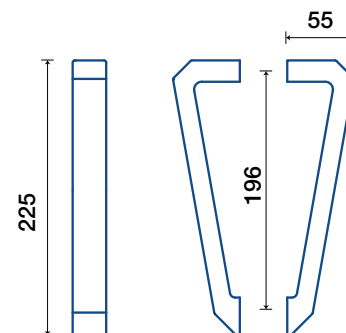

Frascio design



Kalè



Frascio design

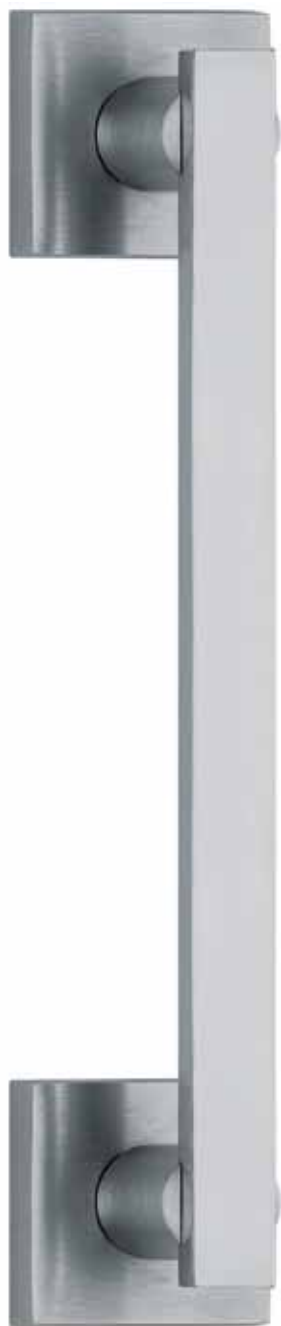

OTTONE/BRASS

FINITURE/FINISHES

CROMO LUCIDO

POLISHED CHROME

CROMO SATINATO

SATIN CHROME

CROMO SATINATO / LUCIDO

SATIN / POLISHED CHROME

651

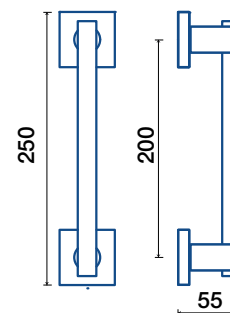

651 UG

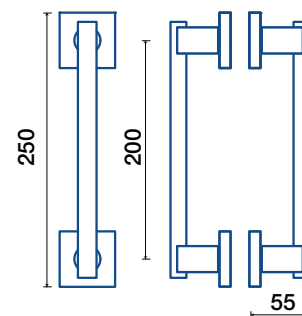

Modulo L



Frascio design



OTTONE/BRASS

FINITURE/FINISHES

CROMO LUCIDO
POLISHED CHROME
CROMO SATINATO
SATIN CHROME
CROMO SATINATO / LUCIDO
SATIN / POLISHED CHROME

792

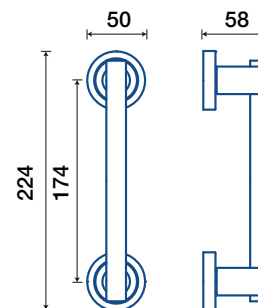

792 UG

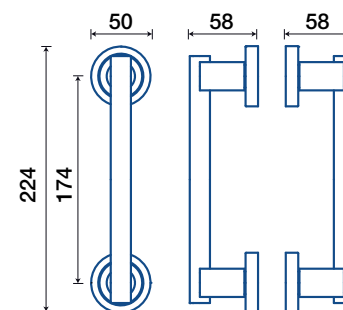

Ibis



Giulio Iacchetti design



OTTONE/BRASS

FINITURE/FINISHES

INOX BRASS
INOX BRASS
OTTONE LUCIDO VERNICIATO
POLISHED BRASS
CROMO SATINATO
SATIN CHROME
ANTRACITE
ANTRACITE

501

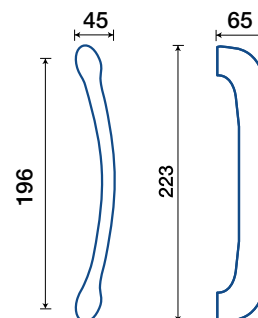

501 UG

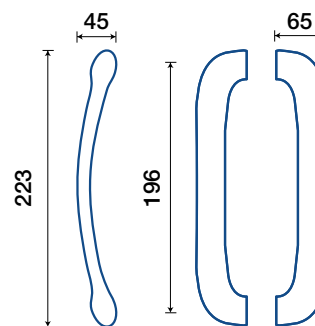

Easy



ZAMA/ZAMAK

FINITURE/FINISHES

INOX BRASS
INOX BRASS
CROMO LUCIDO
POLISHED CHROME
CROMO SATINATO
SATIN CHROME

201

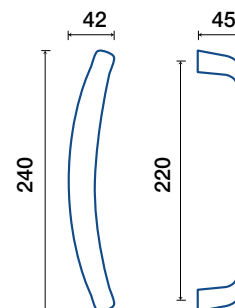

201 UG

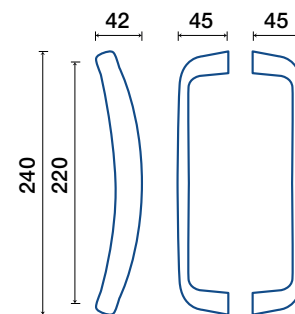

Frascio design

934



Frascio design



OTTONE/ACCIAIO

BRASS/STAINLESS STEEL

FINITURE/FINISHES

BI - INOX

BI - INOX

ACCIAIO SATINATO / CROMO LUCIDO

SATIN STAINLESS STEEL / POLISHED CHROME

934

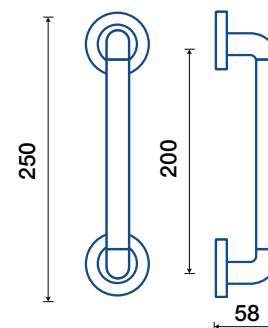

934 UG

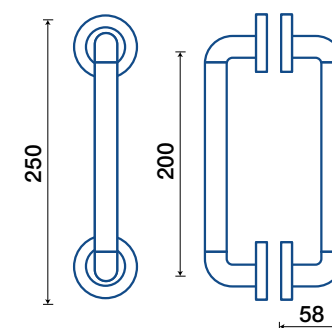

Pavone



OTTONE/BRASS

FINITURE/FINISHES

INOX BRASS
INOX BRASS
OTTONE LUCIDO VERNICIATO
POLISHED BRASS
CROMO SATINATO
SATIN CHROME
ANTRACITE
ANTRACITE

506

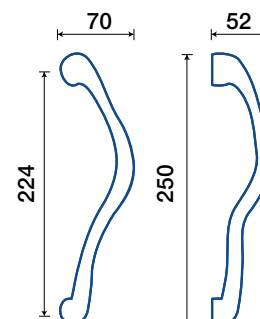

506 UG

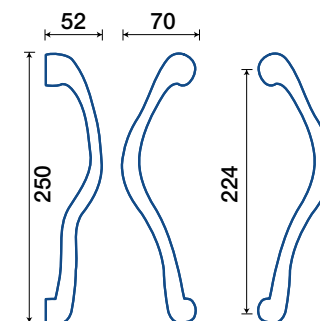

Controdesign design



Fenice



Marcello Ziliani design



OTTONE/BRASS

FINITURE/FINISHES

INOX BRASS
INOX BRASS
OTTONE LUCIDO VERNICIATO
POLISHED BRASS
CROMO SATINATO
SATIN CHROME
ANTRACITE
ANTRACITE

504

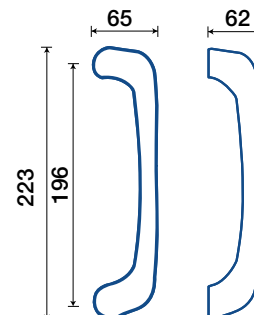

504 UG

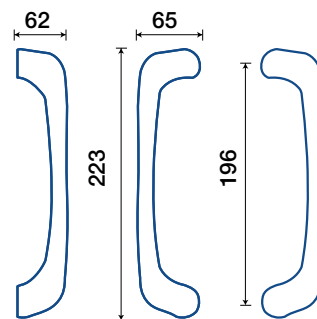

Star



Frascio design



OTTONE/BRASS

FINITURE/FINISHES

OTTONE LUCIDO VERNICIATO
POLISHED BRASS

146/92

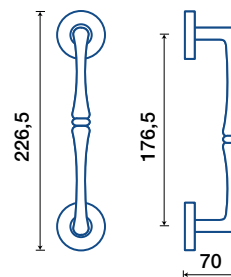

146/92 UG

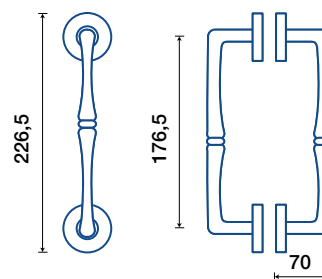

Attila



Frascio design



OTTONE/BRASS

FINITURE/FINISHES

OTTONE LUCIDO VERNICIATO

POLISHED BRASS

BLACK IRON

BLACK IRON

ANTICATO

ANTICATO

666

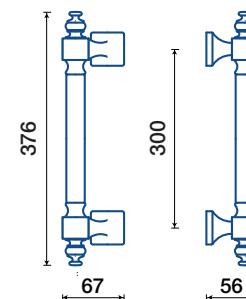

666 UG

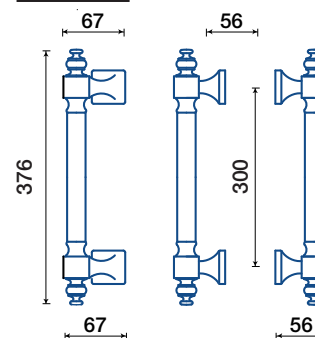

Arpa



OTTONE/BRASS

FINITURE/FINISHES

INOX BRASS

INOX BRASS

INOX CHROME

INOX CHROME



BCF design



350

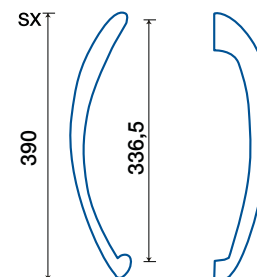

350 UG

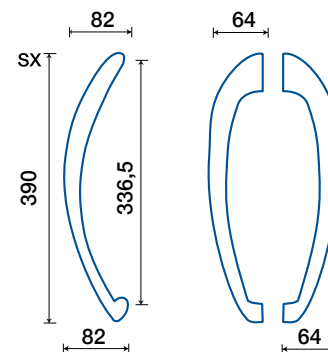

Join QT



OTTONE / ACRILICO - BRASS / ACRYLIC



Giacomo Giustizieri design



FINITURE/FINISHES

CROMO LUCIDO
POLISHED CHROME
CROMO SATINATO
SATIN CHROME
ACCIAIO LUCIDO / CROMO SATINATO
POLISHED STAINLESS STEEL / SATIN CHROME
ACCIAIO SATINATO / CROMO LUCIDO
SATIN STAINLESS STEEL / POLISHED CHROME
ANTRACITE
ANTRACITE

COLORI ACRILICO:
ACRYLIC COLORS:
GHOST
BLANC
DARK
PEPPER

926 / 50 QT

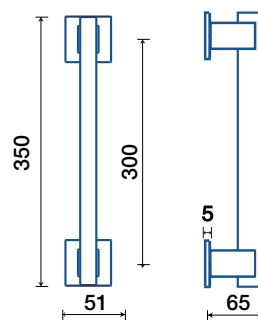

926 / 50 QT UG

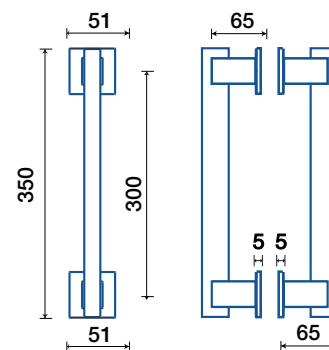

Alzante scorrevole

Pull-up handle for sliding door



OTTONE/BRASS

FINITURE/FINISHES

INOX BRASS
INOX BRASS
OTTONE LUCIDO VERNICIATO
POLISHED BRASS
CROMO SATINATO
SATIN CHROME
ANTRACITE
ANTRACITE

550

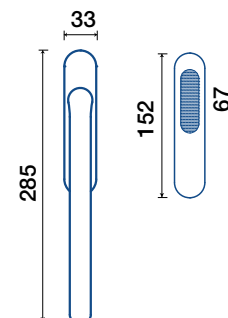

550 UG

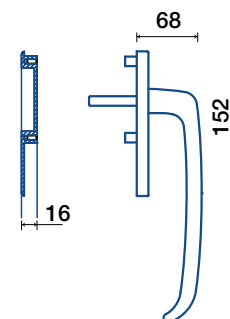

Frascio design



Alzante scorrevole

Pull-up handle for sliding door



OTTONE/BRASS



Frascio design



FINITURE/FINISHES

CROMO LUCIDO
POLISHED CHROME
CROMO SATINATO
SATIN CHROME
ANTRACITE
ANTRACITE

550 Q

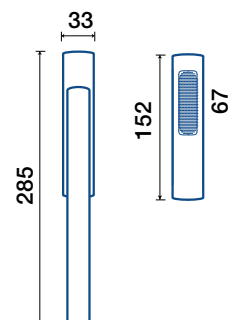

550 Q UG

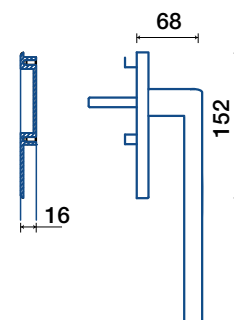

755



Frascio design

755 / 50Q

POMCLOFRSSO 55x55 mm
SINGLE KNOB 55x55 mm

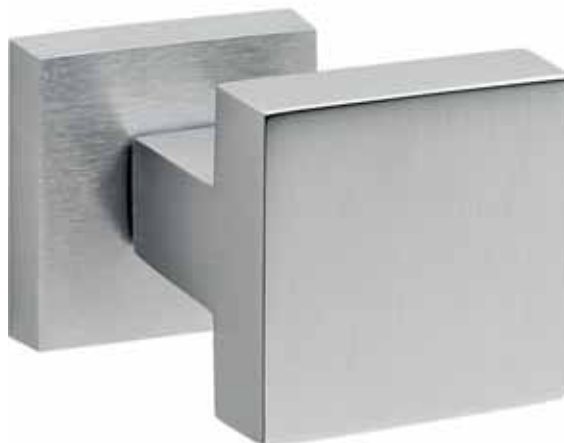
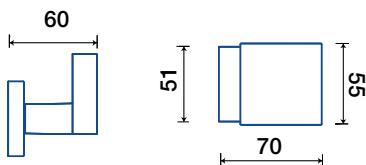

OTTONE/BRASS

FINITURE/FINISHES

CROMO LUCIDO / POLISHED CHROME
CROMO SATINATO / SATIN CHROME
NICKEL SATINATO / SATIN NICKEL
BIANCO / WHITE
BRONZO TEND / BRONZE TEND
LONDON NIGHT LUCIDO
LONDON NIGHT POLISHED
LONDON NIGHT SATINATO
LONDON NIGHT SATIN
RED COPPER LUCIDO / RED COPPER POLISHED
RED COPPER SATINATO / RED COPPER SATIN
GREY STONE / GREY STONE
NERO OPACO / MATT BLACK
OSSIDATO / OSSIDATO
CORTEN / CORTEN
LEATHER / LEATHER
CRACKLE / CRACKLE
ANTRACITE / ANTRACITE

Tuke Glass



Frascio design

756 / 50Q

POMCLOFRSSO 55x55 mm
SINGLE KNOB 55x55 mm

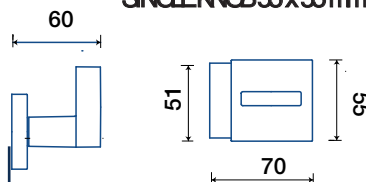

OTTONE/BRASS

FINITURE/FINISHES

CROMO LUCIDO
POLISHED CHROME
CROMO SATINATO
SATIN CHROME



507 coppia



Frascio design

507/501

COPPIA POMOLI CON ROSETTA E
BOCCHETTA
SET KNOBS WITH ROSE AND
ESCUTO-ECN

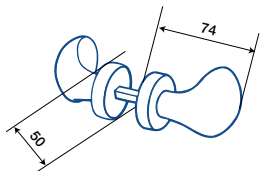

OTTONE/BRASS

FINITURE/FINISHES

INOX BRASS
INOX BRASS
INOX CHROME
INOX CHROME
OTTONE LUCIDO VERNICIATO
POLISHED BRASS
CROMO LUCIDO
POLISHED CHROME
CROMO SATINATO
SATIN CHROME
NICKEL SATINATO
SATIN NICKEL
ANTICATO
ANTICATO

507



Frascio design

507/501

POMOLO FISSO
SINGLE KNOB

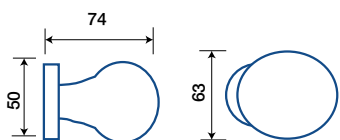

OTTONE/BRASS

FINITURE/FINISHES

INOX BRASS / INOX BRASS
INOX CHROME / INOX CHROME
OTTONE LUCIDO VERNIC. / POLISHED BRASS
CROMO LUCIDO / POLISHED CHROME
CROMO SATINATO / SATIN CHROME
NICKEL SATINATO / SATIN NICKEL
ANTICO OPACO / MATT ANTIQUE BRASS
LONDON NIGHT LUCIDO
LONDON NIGHT POLISHED
LONDON NIGHT SATINATO
LONDON NIGHT SATIN
RED COPPER LUCIDO / RED COPPER POLISHED
RED COPPER SATINATO / RED COPPER SATIN
GREY STONE / GREY STONE
ANTRACITE / ANTRACITE

788 coppia



Frascio design

COPPIA POMOLI
CON ROSETTA E BOCCONETTA
SET KNOBS WITH ROSE AND
ESCUTCHEON

788-60/501 - Ø60mm
788-50/501 - Ø50mm

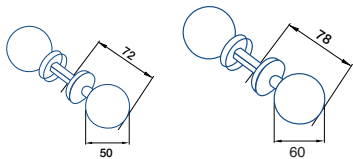

OTTONE/BRASS

FINITURE/FINISHES

INOX BRASS
INOX BRASS
OTTONE LUCIDO VERNICIATO
POLISHED BRASS
CROMO LUCIDO
POLISHED CHROME
CROMO SATINATO
SATIN CHROME

788



Frascio design

POMOLI FISSI/FIXED KNOB

788-70/501 - Ø70mm
788-60/501 - Ø60mm
788-50/501 - Ø50mm

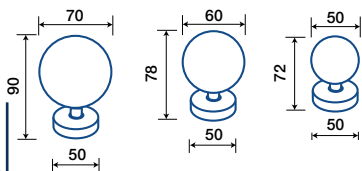

851



Frascio design

851/501
POMCUI FISSO Ø70mm
SINGLE KNOB Ø70mm

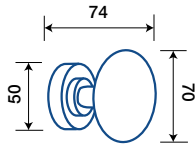

OTTONE/BRASS

FINITURE/FINISHES

OTTONE LUCIDO VERNICIATO
POLISHED BRASS
CROMO SATINATO
SATIN CHROME

Easy



Frascio design

760
POMCUI FISSO
SINGLE KNOB

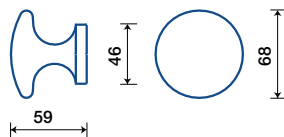

ZAMA/ZAMAK

FINITURE/FINISHES

INOX BRASS
INOX BRASS
CROMO LUCIDO
POLISHED CHROME
CROMO SATINATO
SATIN CHROME

896/45



FINITURE/FINISHES

INOX BRASS
INOX BRASS
INOX CHROME
INOX CHROME
OTTONE LUCIDO VERNICIATO
POLISHED BRASS
OTTONE SATINATO VERNICIATO
SATIN BRASS
CROMO LUCIDO
POLISHED CHROME
CROMO SATINATO
SATIN CHROME
NICKEL SATINATO
SATIN NICKEL

NOTTOLINO WC CON ROSETTA
Ø45 mm
THUMB TURN WITH ROSE Ø45 mm



896/50 I



FINITURE/FINISHES

INOX BRASS
INOX BRASS
INOX CHROME
INOX CHROME
OTTONE LUCIDO VERNICIATO
POLISHED BRASS
OTTONE SATINATO VERNICIATO
SATIN BRASS
CROMO LUCIDO
POLISHED CHROME
CROMO SATINATO
SATIN CHROME
NICKEL SATINATO
SATIN NICKEL
ANTICO OPACO
MATT ANTIQUE BRASS

NOTTOLINO WC CON ROSETTA
Ø50 mm
THUMB TURN WITH ROSE Ø50 mm



896/50 RT



FINITURE/FINISHES

INOX BRASS
 INOX BRASS
 CROMO LUCIDO
 POLISHED CHROME
 CROMO SATINATO
 SATIN CHROME
 NICKEL SATINATO
 SATIN NICKEL
 LONDON NIGHT LUCIDO
 LONDON NIGHT POLISHED
 LONDON NIGHT SATINATO
 LONDON NIGHT SATIN
 RED COPPER LUCIDO
 RED COPPER POLISHED
 RED COPPER SATINATO
 RED COPPER SATIN
 GREY STONE
 GREY STONE
 ANTRACITE
 ANTRACITE

NOTTO LINO WC CON ROSETTA
 Ø50 mm
 THUMB TURN WITH ROSE Ø50 mm

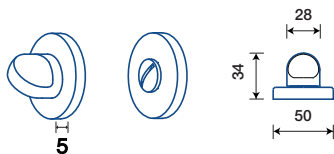

896/50 R



FINITURE/FINISHES

INOX BRASS
 INOX BRASS
 OTTONE LUCIDO VERNICIATO
 POLISHED BRASS
 CROMO LUCIDO
 POLISHED CHROME
 CROMO SATINATO
 SATIN CHROME
 NICKEL SATINATO
 SATIN NICKEL
 ANTICATO
 ANTICATO
 BLACK IRON
 BLACK IRON

NOTTO LINO WC CON ROSETTA
 Ø50 mm
 THUMB TURN WITH ROSE Ø50 mm



896/K 52

NOTTOLINO WC CON ROSETTA
Ø52mm
THUMB TURN WITH ROSE Ø52mm



FINITURE/FINISHES

ACCIAIO LUCIDO
POLISHED STAINLESS STEEL
ACCIAIO SATINATO
SATIN STAINLESS STEEL

895/50 Q



FINITURE/FINISHES

CROMO LUCIDO / POLISHED CHROME
CROMO SATINATO / SATIN CHROME
NICKEL SATINATO / SATIN NICKEL
BIANCO / WHITE
BRONZO TREND / BRONZE TREND
LONDON NIGHT LUCIDO
LONDON NIGHT POLISHED
LONDON NIGHT SATINATO
LONDON NIGHT SATIN
RED COPPER LUCIDO
RED COPPER POLISHED
RED COPPER SATINATO
RED COPPER SATIN
GREY STONE / GREY STONE
NERO OPACO / BLACK MATT
CORTEN / CORTEN
CRACKLÉ / CRACKLÉ
OSSIDATO / OSSIDATO
LEATHER / LEATHER

NOTTOLINO WC CON ROSETTA
QUADRATA
THUMB TURN WITH SQUARE ROSE

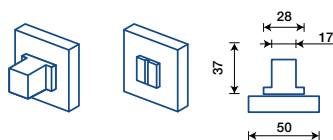

895/50 QT



FINITURE/FINISHES

CROMO LUCIDO
POLISHED CHROME
CROMO SATINATO
SATIN CHROME
NICKEL SATINATO
SATIN NICKEL
BIANCO
WHITE
NERO OPACO
BLACK MATT
ANTRACITE
ANTRACITE

NOTTOLINO WC CON ROSETTA
BASSA QUADRATA
THUMB TURN WITH THIN SQUARE
ROSE

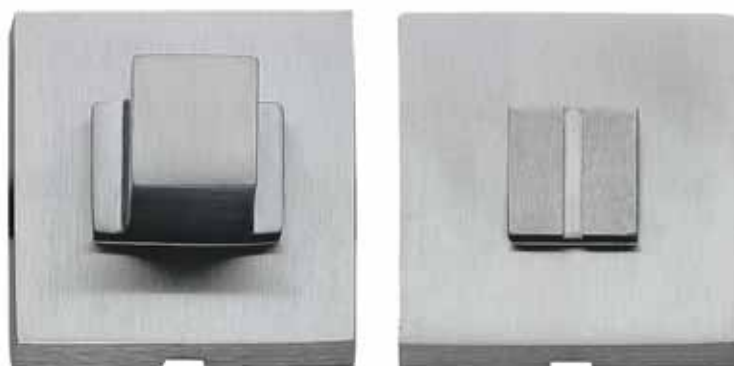
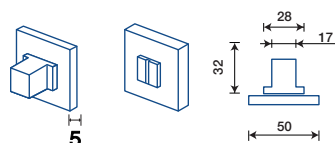

895/51 Q

FINITURE/FINISHES

ACCIAIO LUCIDO
POLISHED STAINLESS STEEL
ACCIAIO SATINATO
SATIN STAINLESS STEEL
CROMO LUCIDO
POLISHED CHROME
CROMO SATINATO
SATIN CHROME

NOTTOLINO WC CON ROSETTA
QUADRATA
THUMB TURN WITH SQUARE ROSE

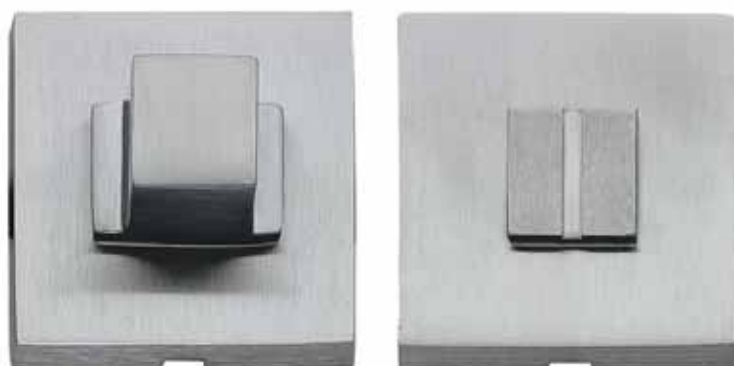
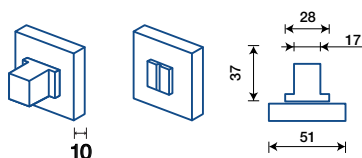

896/50 QR

NOTTOLINO WC CON ROSETTA
QUADRATA CON ANGOLI
RAGGIATI
THUMB TURN WITH RADIUS
SQUARE ROSE

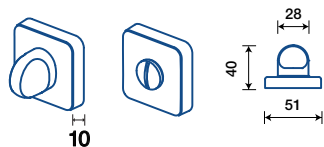

FINITURE/FINISHES

CROMO LUCIDO
POLISHED CHROME
CROMO SATINATO
SATIN CHROME

45

BUCCHETTA Ø45 mm
ESCUTCONE Ø45 mm

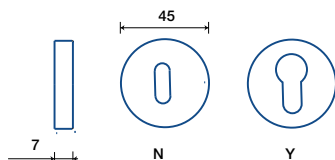

FINITURE/FINISHES

INOX BRASS
INOX BRASS
INOX CHROME
INOX CHROME
OTTONE LUCIDO VERNICIATO
POLISHED BRASS
OTTONE SATINATO VERNICIATO
SATIN BRASS
CROMO LUCIDO
POLISHED CHROME
CROMO SATINATO
SATIN CHROME
NICKEL SATINATO
SATIN NICKEL

50 I

BOCCHETTA Ø50 mm
ESCUITO-ECN Ø50 mm

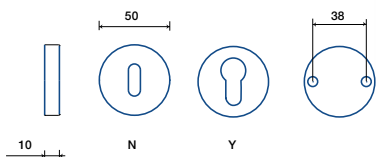

FINITURE/FINISHES

INOX BRASS
INOX BRASS
INOX CHROME
INOX CHROME
OTTONE LUCIDO VERNICIATO
POLISHED BRASS
OTTONE SATINATO VERNICIATO
SATIN BRASS
CROMO LUCIDO
POLISHED CHROME
CROMO SATINATO
SATIN CHROME
NICKEL SATINATO
SATIN NICKEL
ANTICO OPACO
MATT ANTIQUE BRASS

50 RT

BOCCHETTA BASSA Ø50 mm
THIN ESCUITO-ECN Ø50 mm

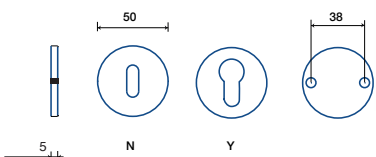

FINITURE/FINISHES

INOX BRASS
INOX BRASS
CROMO LUCIDO
POLISHED CHROME
CROMO SATINATO
SATIN CHROME
NICKEL SATINATO
SATIN NICKEL
LONDON NIGHT LUCIDO
LONDON NIGHT POLISHED
LONDON NIGHT SATINATO
LONDON NIGHT SATIN
RED COPPER LUCIDO
RED COPPER POLISHED
RED COPPER SATINATO
RED COPPER SATIN
GREY STONE
GREY STONE
ANTRACITE
ANTRACITE

50 R



BOCCHETTA Ø50 mm
ESCUITO-ECN Ø50 mm

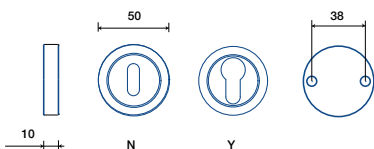

FINITURE/FINISHES

INOX BRASS
INOX BRASS
OTTONE LUCIDO VERNICIATO
POLISHED BRASS
CROMO LUCIDO
POLISHED CHROME
CROMO SATINATO
SATIN CHROME
NICKEL SATINATO
SATIN NICKEL
ANTICATO
ANTICATO
BLACK IRON
BLACK IRON

K 52

BOCCHETTA Ø52 mm
ESCUITO-ECN Ø52 mm

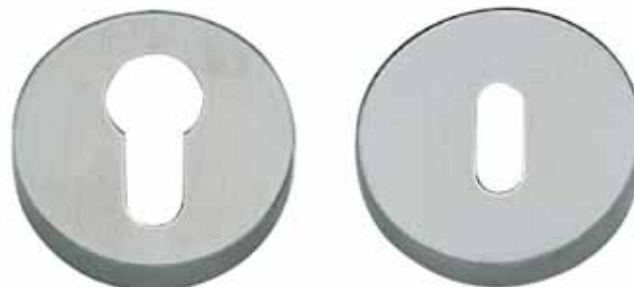
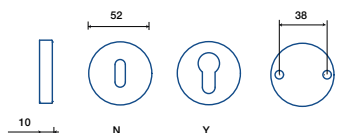

FINITURE/FINISHES

ACCIAIO LUCIDO
POLISHED STAINLESS STEEL
ACCIAIO SATINATO
SATIN STAINLESS STEEL

50 Q

BOCCHETTA QUADRATA
SQUARE ESCUTCHEON

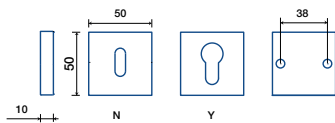

FINITURE/FINISHES

CROMO LUCIDO / POLISHED CHROME
 CROMO SATINATO / SATIN CHROME
 NICKEL SATINATO / SATIN NICKEL
 BRONZO TEND / BRONZE TEND
 LONDON NIGHT LUCIDO
 LONDON NIGHT POLISHED
 LONDON NIGHT SATINATO
 LONDON NIGHT SATIN
 RED COPPER LUCIDO
 RED COPPER POLISHED
 RED COPPER SATINATO
 RED COPPER SATIN
 GREY STONE / GREY STONE
 BIANCO / WHITE
 NEFO OPAO / BLACK MATT
 CORTEN / CORTEN
 CRACKLÉ / CRACKLÉ
 LEATHER / LEATHER
 OSSIDATO / OSSIDATO

50 QT

BOCCHETTA QUADRATA BASSA
THIN SQUARE ESCUTCHEON

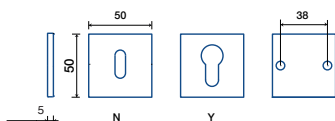

FINITURE/FINISHES

CROMO LUCIDO
 POLISHED CHROME
 CROMO SATINATO
 SATIN CHROME
 NICKEL SATINATO
 SATIN NICKEL
 BRONZO TEND
 BRONZE TEND
 BIANCO
 WHITE
 NEFO OPAO
 BLACK MATT
 ANTRACITE
 ANTRACITE

51 Q

BOCCHETTA QUADRATA
SQUAFESCUTCHEON

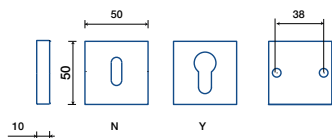

FINITURE/FINISHES

ACCIAIO LUCIDO
POLISHED STAINLESS STEEL
ACCIAIO SATINATO
SATIN STAINLESS STEEL
CROMO LUCIDO
POLISHED CHROME
CROMO SATINATO
SATIN CHROME

50 QR

BOCCHETTA QUADRATA CON
ANGOLI RAGGIATI
RADIUS SQUAFESCUTCHEON

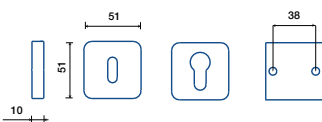

FINITURE/FINISHES

CROMO LUCIDO
POLISHED CHROME
CROMO SATINATO
SATIN CHROME

32 PO



BOCCHETTA OVALE
OVALESCUTCHEON

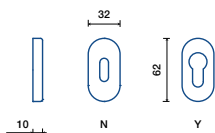

FINITURE/FINISHES

INOX BRASS
INOX BRASS
INOX CHROME
INOX CHROME
OTTONE LUCIDO VERNICIATO
POLISHED BRASS
OTTONE SATINATO VERNICIATO
SATIN BRASS
CROMO LUCIDO
POLISHED CHROME
CROMO SATINATO
SATIN CHROME
NICKEL SATINATO
SATIN NICKEL
ANTICO OPACO
MATT ANTIQUE BRASS
ANTRACITE
ANTRACITE

31 Q



BOCCHETTA RETTANGOLARE
RECTANGULARESCUTCHEON

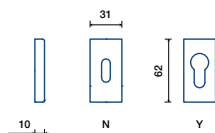

FINITURE/FINISHES

ACCIAIO SATINATO
SATIN STAINLESS STEEL
OTTONE LUCIDO VERNICIATO
POLISHED BRASS
OTTONE SATINATO VERNICIATO
SATIN BRASS
CROMO LUCIDO
POLISHED CHROME
CROMO SATINATO
SATIN CHROME
NICKEL SATINATO
SATIN NICKEL
ANTRACITE
ANTRACITE

Fermaporte 540

Door-stop

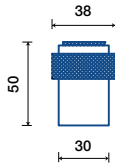

FINITURE/FINISHES

OTTONE LUCIDO VERNICIATO
 POLISHED BRASS
 CROMO LUCIDO
 POLISHED CHROME
 CROMO SATINATO
 SATIN CHROME
 ANTRACITE
 ANTRACITE

Fermaporte 541

Door-stop

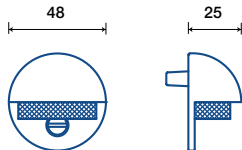

FINITURE/FINISHES

OTTONE LUCIDO VERNICIATO
 POLISHED BRASS
 CROMO LUCIDO
 POLISHED CHROME
 CROMO SATINATO
 SATIN CHROME

Chiave 510

Key

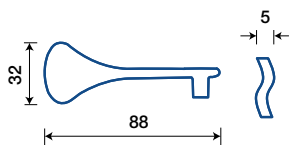

FINITURE/FINISHES

INOX BRASS
 INOX BRASS
 OTTONE LUCIDO VERNICIATO
 POLISHED BRASS
 CROMO LUCIDO
 POLISHED CHROME
 CROMO SATINATO
 SATIN CHROME

Set per porte blindate Easy

Kit for security door

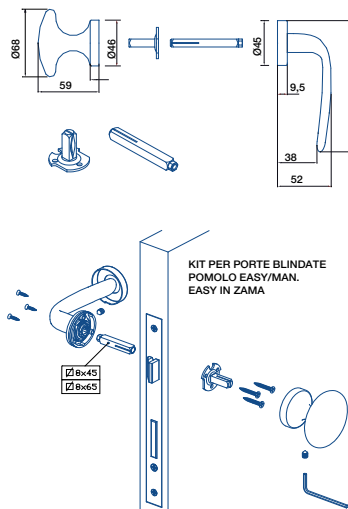

FINITURE/FINISHES

INOX BRASS
INOX BRASS
CROMO LUCIDO
POLISHED CHROME
CROMO SATINATO
SATIN CHROME

400 DK

MECCANISMO CON CILINDRO
E CHIAVE

MECHANISM WITH CYLINDER
AND KEY

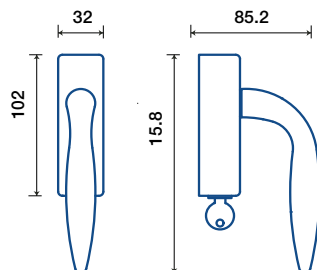

FINITURE/FINISHES

INOX BRASS
INOX BRASS
INOX CHROME
INOX CHROME
OTTONE LUCIDO VERNICIATO
POLISHED BRASS
CROMO LUCIDO
POLISHED CHROME
CROMO SATINATO
SATIN CHROME

Movimenti per finestra / Window mechanism

A MOVIMENTO DK-OP

DK MECHANISM WITH PINS



B MOVIMENTO DK PASATO

DK MECHANISM WITHOUT PINS



C MOVIMENTO CREMONESE

WINDOWS MECHANISM FOR PLATE



D MOVIMENTO CREMONESE

WINDOWS MECHANISM FOR PLATE



E MOVIMENTO CREMONESE

WINDOWS MECHANISM FOR PLATE



**MOVIMENTO CREMONESE
ECONOMICO PER PIASTRINA
CON FORI ART 30 F GRATZ CON
BUCCOLE + Q7**

WINDOWS MECHANISM FOR
PLATE ART 30 F GRATZ WITH
BUSHES + 7mm SPINDLE

**MOVIMENTO CREMONESE
ECONOMICO PER PIASTRINA
CON FORI ART 30 F GRATZ CON
PERNI**

WINDOWS MECHANISM FOR
PLATE ART 30 F GRATZ WITH PINS

**MOVIMENTO CREMONESE
ECONOMICO PER PIASTRINA
CON FORI ART 30 F GRATZ CON
BUCCOLE**

WINDOWS MECHANISM FOR
PLATE ART 30 F GRATZ WITH
BUSHES

F MOVIMENTO CREMONESE

WINDOWS MECHANISM FOR PLATE



MOVIMENTO CREMONESE
LUSSO PER PIASTRINA SENZA
FORI ART 30 MARTELLINA Q7
WINDOWS MECHANISM FOR PLATE
ART 30 + 7mm SPINDLE

G MOVIMENTO CREMONESE

WINDOWS MECHANISM FOR PLATE



MOVIMENTO CREMONESE
LUSSO PER PIASTRINA SENZA
FORI ART 30 GRATZ CON BUCCOLE
WINDOWS MECHANISM FOR PLATE
ART 30 GRATZ WITH BUSHES + 7 mm
SPINDLE

H MOVIMENTO CREMONESE

WINDOWS MECHANISM FOR PLATE



MOVIMENTO CREMONESE
LUSSO PER PIASTRINA SENZA
FORI ART 30 GRATZ CON PERNI
WINDOWS MECHANISM FOR PLATE
ART 30F GRATZ WITH PINS

I MOVIMENTO CREMONESE

WINDOWS MECHANISM FOR PLATE



MOVIMENTO CREMONESE
LUSSO PER PIASTRINA SENZA
FORI ART 30 GRATZ CON BUCCOLE
WINDOWS MECHANISM FOR PLATE
ART 30 GRATZ WITH BUSHES

Base per pomolo fisso / Dummy base system

BASE PER POMOLO FISSO

FIXED KNOB BASE

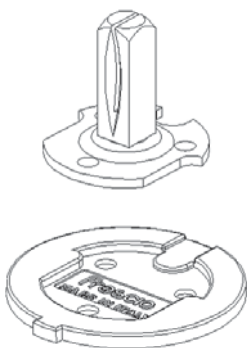

BASE PER POMOLO FISSO
PER ROSETTA 50I-50R-50Q-50QR
FIXED KNOB BASE FOR ROSES
50I-50R-50Q-50QR

Espositori/Displays

ESPOSITORE COMPONIBILE / PLEXIGLASS ESTRAIBILI

MODULAR DISPLAY / EXTRACTABLE PLEXIGLASS

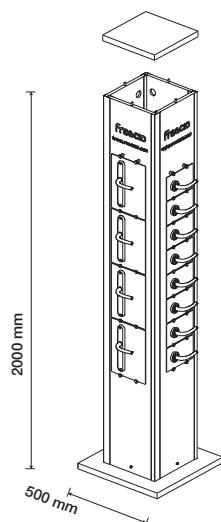

ESPOSITORE DA PARETE / PLEXIGLASS ESTRAIBILI

WALL DISPLAY / EXTRACTABLE PLEXIGLASS

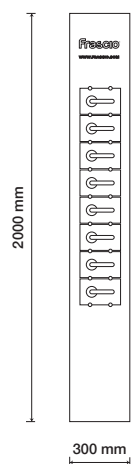

Frascio s.r.l.

Via Nazionale 6

25074 Lavenone (BS) Italia

Tel. +39 0365 839001

Fax. +39 0365 83578

e-mail: info@frascio.it

www.frascio.com